

HOESCH® PRODUCTS AND SYSTEMS



THE ORIGINAL: THE FUTURE!



Products and Systems

at a glance





CONTENTS

Roof

- 8 Hoesch® Thermodach
- 9 Hoesch isodach mono®
- 10 Hoesch isodach integral®
- 11 Hoesch isowelle® Roof
- 12 Hoesch isorock® integral D
- 13 Hoesch® 2000 Roof System
- 14 Hoesch® Arched Roof
- 15 Hoesch® Trapezoidal Sheet

Wall

- 18 Hoesch® Thermowand
- 19 Hoesch® Thermowand TL
- 20 Hoesch isowand integral®
- 22 Hoesch isowand integral® FSI
- 23 Hoesch® isowand design
- 24 Hoesch isowelle®
- 25 Hoesch isowand vario®
- 26 ems-isolier® Cold Store Panel PU
- 28 Hoesch isorock®
- 29 Hoesch isorock® vario
- 30 Hoesch isorock® acoustic
- 31 Hoesch® Polygon Arch
- 32 Hoesch® trapezoidal profile
- 33 Hoesch® acoustic
- 34 Hoesch Planeel® Siding
- 36 Hoesch® Corrugated Profile
- 37 Hoesch® Liner Tray

Coating

- 44 Coatingsystems

Accessories

- 46 Flashings and accessories

Floor

- 40 Hoesch Additiv Floor®
- 42 ems-isolier® Cold Store Panel PU
- 43 Hoesch isorock®



Our logo has a whole new look and feel, to support a better organization of our product portfolio. We have used three colours to identify the different application areas, i.e.:

- » roof (blue)
- » wall (green)
- » floor (brown)

This means you can see at a glance where the products you are viewing can be applied. If a product can be used for various applications, the different symbols can be found beside the product description.

Taking our heritage to the next level

Our commitment to quality for building systems



Take advantage of our expertise

For decades, Hoesch® and ems-isolier® building products have been a hallmark for quality and innovation for exacting industrial and commercial buildings. The world's first continuous production line for sandwich elements was commissioned as early as the 1960s. The experience that we have gained over 40 years gives you reassurance, now and in the future. Our commitment to quality includes roofs, walls, and floors:

Guarantee

Together with our prematerial suppliers, we offer extensive guarantees for our coating systems. The use of high-grade metallic finishes, as well as cutting-edge coating systems ensure outstanding corrosion protection.

Sustainability

Sustainable construction projects which use our building systems together with our total guarantee for building envelopes help save resources and cut energy costs by up to 40%.

Colours

You can choose from over 150 standard colours and individual shades.

Coating

A large selection of coating systems means you can select the ideal surface for your application.

Shape

We offer holistic building envelope solutions including planning and supply, as well as Hoesch Firetec® certified fire protection systems and optimal joint tightness. Installation by certified contractors guarantees that products will be correctly fitted so that you can benefit fully from their energy efficiency.



Dependable fire protection using Firetec®

Firetec® systems meet the requirements of FM Global, the Loss Prevention Certifications Board, and European fire resistance class EN 13501. Both FM and LPCB are approved by investors, property insurers and engineers for their excellent fire resistance, reducing the risk of fire. This is a major factor insurance companies are assessing a property. It helps protect life and property and ensures uninterrupted business.

Firetec® systems are available with a PIR or mineral wool core – a perfect solution for every application!





Product features

- » Steel grades for sandwich panels and trapezoidal profiles: S320GD, Z 275
- » All insulation materials used are fully recyclable
- » Special coatings of the brands PLADUR® Wrinkle, PLADUR® Relief and PLADUR® L on request (PLADUR® is a registered trademark of ThyssenKrupp Steel Europe AG)
- » Insulation cores free from CFC and HCFC
- » All Hoesch Bausysteme GmbH products are manufactured in line with EN 14509
- » Many items made by Hoesch Bausysteme GmbH are subject to the EPAQ quality directives
- » General approval issued by the German building inspectorate (Z-10.4-345) and approvals issued by many foreign authorities
- » Element length up to 24 m
- » Alternative cover sheets on request
- » Certified contractors ensure expert installation

More information on guarantee and warranty can be found in our guarantee brochure Info 7.2.0 (from 03.2013).

Building products made by Hoesch Building Systems comply with the applicable European guidelines.

As of 1.10.09 the EnEV also applies to industrial buildings. Many of our products already comply with the stringent requirements specified in the amendment to this regulation. The products concerned are marked. If you have queries, please contact us.

EPAQuality defines European quality standards and thus ensures the quality of building systems.



Above the rooftops of the future
with roof systems made by Hoesch®



Roof Systems

Hoesch® Thermodach

Hoesch isodach mono®

Hoesch isodach integral®

Hoesch isowelle® Roof

Hoesch isorock® integral D

Hoesch® Roof System 2000

Hoesch® Arched Roof

Hoesch® Trapezoidal Sheet

Some roofs are the epitome of shelter. Others are a point of transition from a building to its environment. No matter what a roof means to you, the broad selection of roof systems and features offered by Hoesch Building Systems has many options for you to choose from. Our products are designed to meet your requirements perfectly in shape and function. All of our bespoke systems and solutions are marked by their short construction periods and economical efficiency. From the sweeping Hoesch® Arched Roof through top-notch design roofs to plain sandwich panels: all of our roofs share a number of common features:

- » Rapid and easy installation
- » Low dead weight
- » High load-bearing capacity
- » Excellent corrosion protection
- » Vapour-tight cover sheets made from coil-coated coloured steel
- » Long life span
- » Outstanding insulation values
- » Large spans
- » Precise joint geometry
- » Almost maintenance-free and durable
- » Optimum resistance to weathering
- » Special Wrinkle and Relief coatings
- » All polyurethane rigid foam cores are available with PUR or PIR rigid foam

Hoesch® Thermodach

Proven technology for the economically conscious



Hoesch® Thermodach offers excellent value for money. It uses through-bolt fastening and comes ready for installation. The PU sandwich roof panels convince by their impressive structural analysis and excellent U values.

Triplex system:

1. Outer seal prevents the ingress of water from upper surface
2. Inner seal to complete the vapour barrier
3. Middle seal to compensate tolerance for the thermal insulation

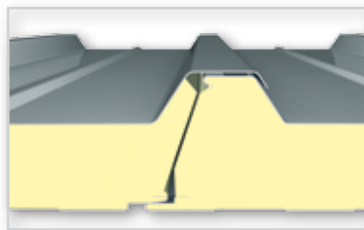
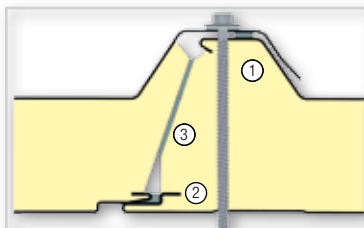

For more technical information about the product, visit:
www.hoesch-bau.com



Product features

- » 3-rib top sheet
- » Behaviour in fire up to B-s2, d0; according to EN 13501-1
- » General approval issued by the German building inspectorate (Z-10.49-533) and approvals issued by many foreign authorities
- » Available in lengths up to 24 m
- » Optimal joint sealing with the Triplex system
- » Available in panel thicknesses 75 mm, 95 mm, 115 mm and 130 mm
- » U-values according to EN 14509 from 0.53 to 0.23 W/m²K

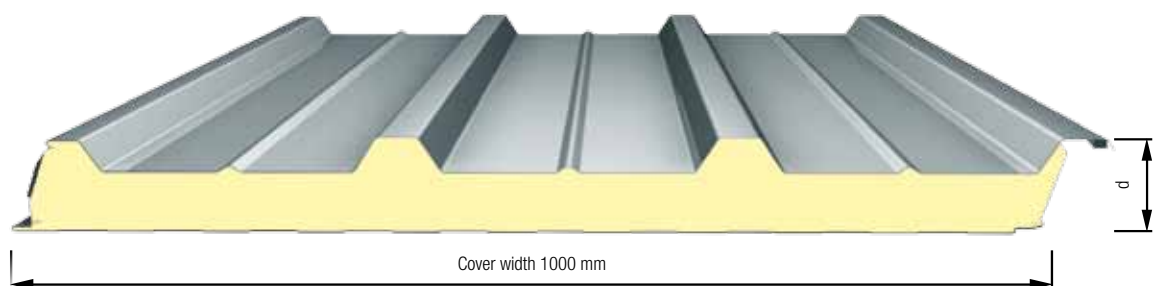

Hoesch isodach mono[®]

Exemplary design in every respect



The Hoesch isodach mono[®] roof system is attractive and prestigious. Small to medium-sized roof apertures are easy to create. Concealed fastening guarantees best results in terms of visual appearance and architectural design.

Product features

- » Prestigious appearance with only one rib per element
- » Simple to make openings thanks to 912 mm wide upper chord without ribs
- » Available in lengths up to 24 m
- » Behaviour in fire up to B-s2, d0; standard C-s3, d0 according to EN 13501-1
- » General approval issued by the German building inspectorate (Z-10.49-533) and approvals issued by many foreign authorities
- » Optimal joint sealing with the Triplex system
- » Available in panel thicknesses 115 mm, 135 mm and 155 mm
- » U-values according to EN 14509 from 0.38 to 0.19 W/m²K

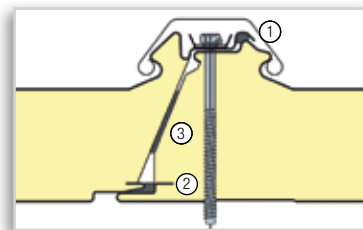

Triplex system:

1. Outer seal prevents the ingress of water from upper surface
2. Inner seal to complete the vapour barrier
3. Middle seal to compensate tolerance for the thermal insulation



For more technical information about the product, visit:
www.hoesch-bau.com

Profiling of cover sheets	Slightly profiled (L)	Microprofiled (M)	V profiled (V)	Flat (E)
Outer sheet	●		●	■
Inner sheet	●			

● available

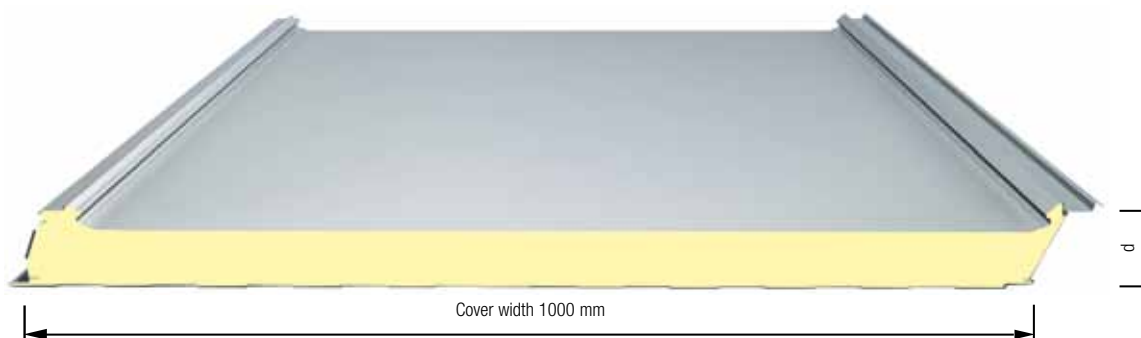

Hoesch isodach integral®

An open view to appealing perspectives

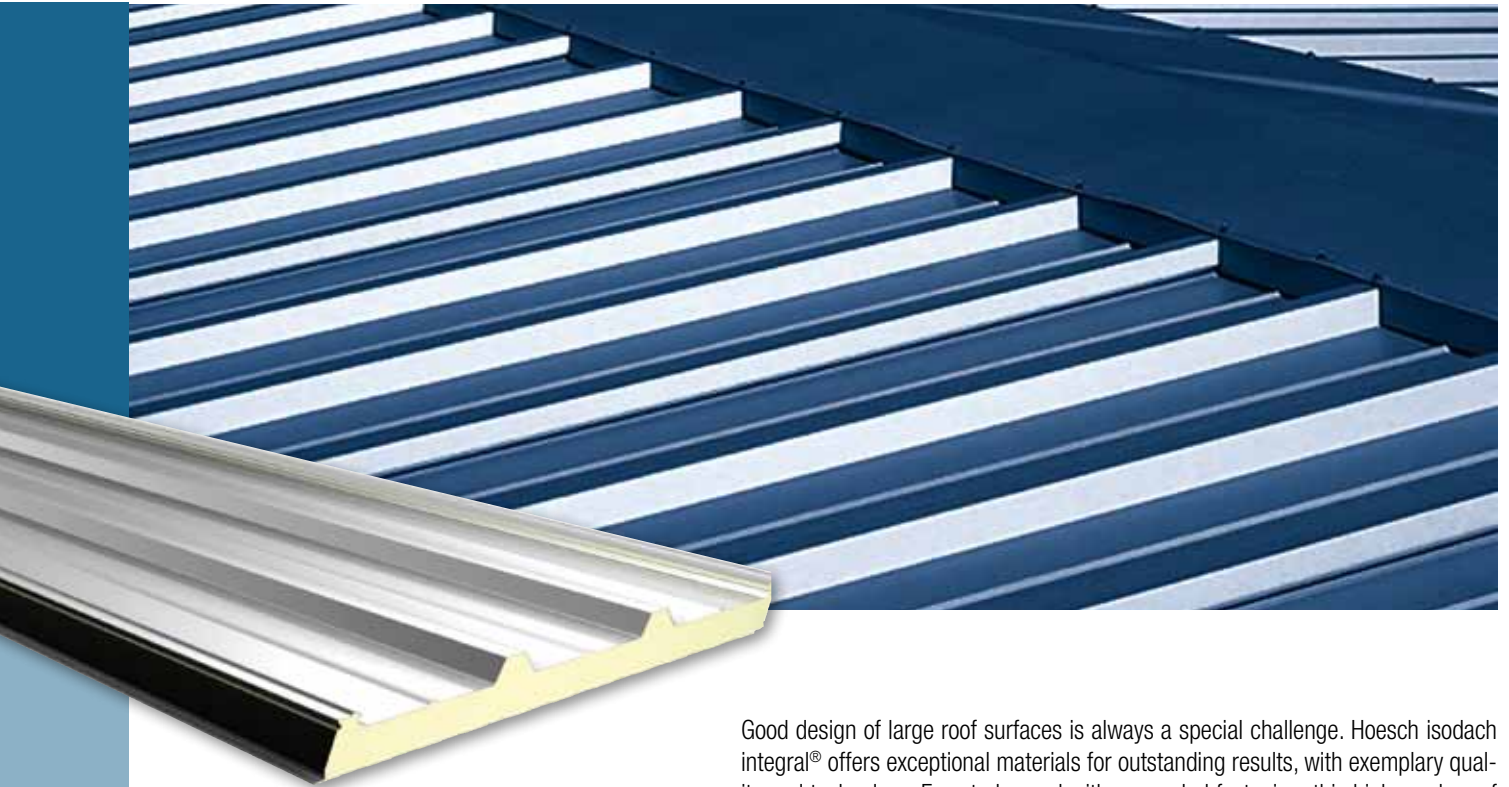

Good design of large roof surfaces is always a special challenge. Hoesch isodach integral® offers exceptional materials for outstanding results, with exemplary quality and technology. Easy to lay and with concealed fastening, this high-grade roof system reaffirms your commitment to top results.

Triplex system:

1. Outer seal prevents the ingress of water from upper surface
2. Inner seal to complete the vapour barrier
3. Middle seal to compensate tolerance for the thermal insulation

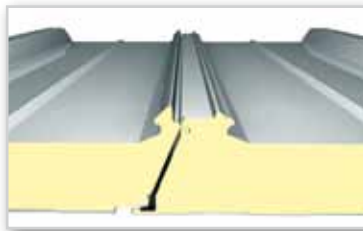
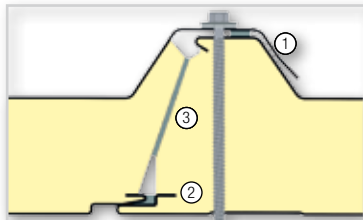

For more technical information about the product, visit:
www.hoesch-bau.com



Product features

- » PU core provides excellent thermal insulation
- » Simple mounting thanks to optimised joint design allows short mounting times and low project costs
- » 3-rib top sheet ensures high load-bearing capacity
- » Behaviour in fire up to B-s2, d0; standard C-s3, d0 according to EN 13501-1
- » General approval issued by the German building inspectorate (Z-10.49-533) and approvals issued by many foreign authorities
- » Optimal joint sealing with the Triplex system
- » Available in lengths up to 24 m
- » Available in panel thicknesses 75 mm, 95 mm, 115 mm, 135 mm and 155 mm
- » U-values according to EN 14509 from 0.53 to 0.18 W/m²K

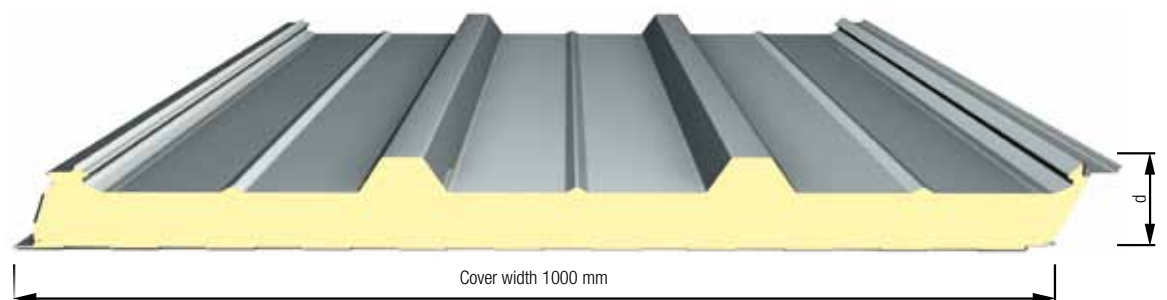

Hoesch isowelle® Roof

Made to defy wind and all types of weather

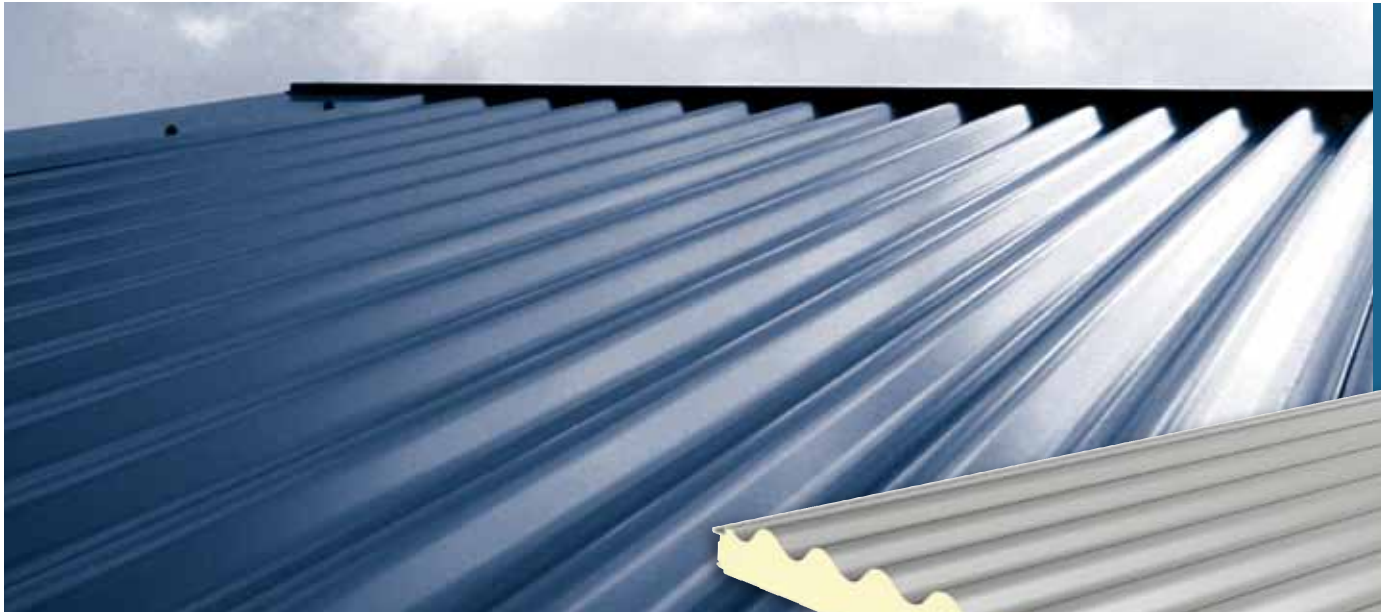

Suitable for roof pitches from 10°, Hoesch isowelle® Roof with concealed fastening is an attractive eye. Fascinating possibilities are waiting for you to implement your creative ideas – producing a wave of enthusiasm.

Product features

- » Corrugated outer sheet
- » Available in lengths up to 20 m
- » Minimum roof pitch $\geq 10^\circ$
- » Behaviour in fire up to B-s2, d0; standard C-s3, d0 according to EN 13501-1
- » General approval issued by the German building inspectorate (Z-10.49-533) and approvals issued by many foreign authorities
- » Available in panel thicknesses 84 mm and 104 mm
- » U-values according to EN 14509 from 0.36 to 0.26 W/m²K

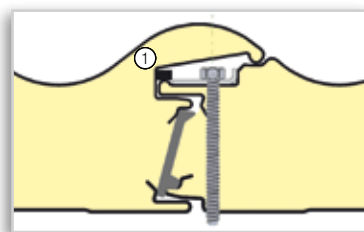

1. Install factory-supplied sealing tape with mounting

For more technical information about the product, visit:
www.hoesch-bau.com

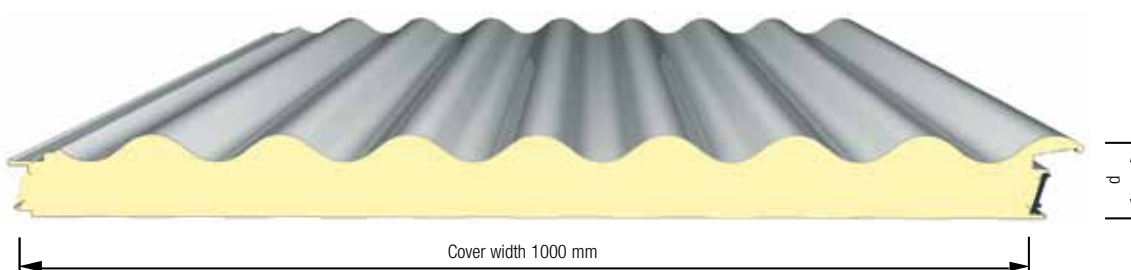

Hoesch isorock® integral D

Convenience and safety



Hoesch isorock® integral D-sandwich roof elements are classified as „non combustible“. They are ideal wherever there are increased requirements for fire protection.

Product features

- » Defined fire resistance classes between 30 and 90 minutes (depending on the type and thickness of the mineral wool used), measured in accordance with national and European standards
- » Behaviour in fire of sandwich panels A2-s1, d0 “non combustible”, classified in accordance with EN 13501-1
- » Behaviour in fire of the physiologically harmless rockwool core A1 “non combustible”, classified in accordance with EN 13501-1
- » Concealed fastening
- » High thermal insulation by saving element ribs, almost complete use of the element nominal height
- » General approval issued by the German building inspectorate (Z-10.49-534)
- » General test certificate issued by the German building inspectorate (P-SAC 02/III-429)
- » Available in lengths up to 18 m
- » Available in panel thicknesses 95 mm, 115 mm, 135 mm and 155 mm
- » U-values according to EN 14509 from 0.49 to 0.28 W/m²K

For more technical information about the product, visit: www.hoesch-bau.com



Profiling of cover sheets	Slightly profiled (L)	Microprofiled (M)	V profiled (V)	Flat (E)
Outer sheet	●	●	●	■
Inner sheet	●			■

● available / ■ on request



Hoesch® 2000 Roof System

Function-based technology with added value



The Hoesch® 2000 Roof System can be used as a load-bearing roof element for conventional non-ventilated roofs and double-sheet roof structures. As prescribed in the official approval, it can also be designed as a shear plane. It can be installed on steel, concrete or wooden substructures. Special cleats are provided for load transfer onto the load-bearing substructure, which explains the high loadbearing capacity of the Hoesch® 2000 Roof System. Special mounting strips ensure a perfect fit for the cleats and help to fasten the trapezoidal panels of the roof system conveniently yet precisely without the need for laborious control measurements. Together with a low dead weight, this allows for fast, easy and economic installation even under unfavourable climatic conditions and irrespective of the building height.

Product features

- » Low dead weight
- » Appealing visual appearance (lower side)
- » General approval issued by the German building inspectorate (Z-14.1-137)
- » Unrestricted high load-bearing capacity even with acoustic perforations
- » Extremely large spans achieved by cantilever girder systems

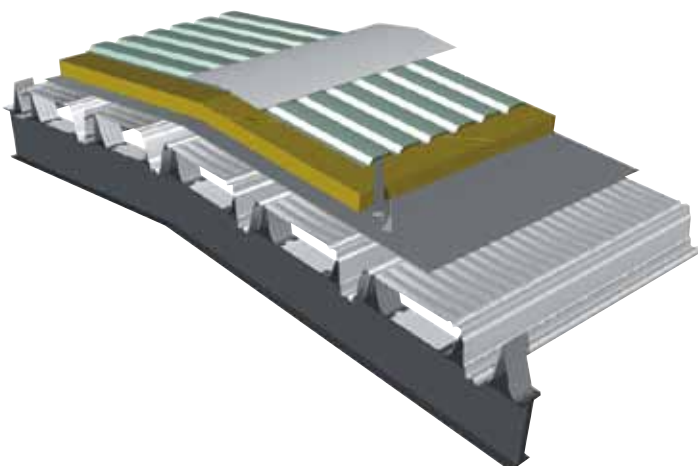

Hole pattern 1:1

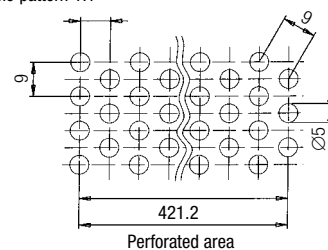

Upper chord perforated

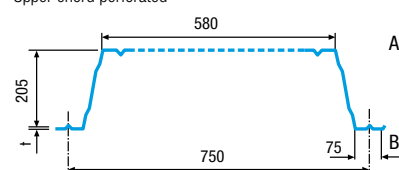

Hoesch® Arched Roof

Timeless elegance, naturally

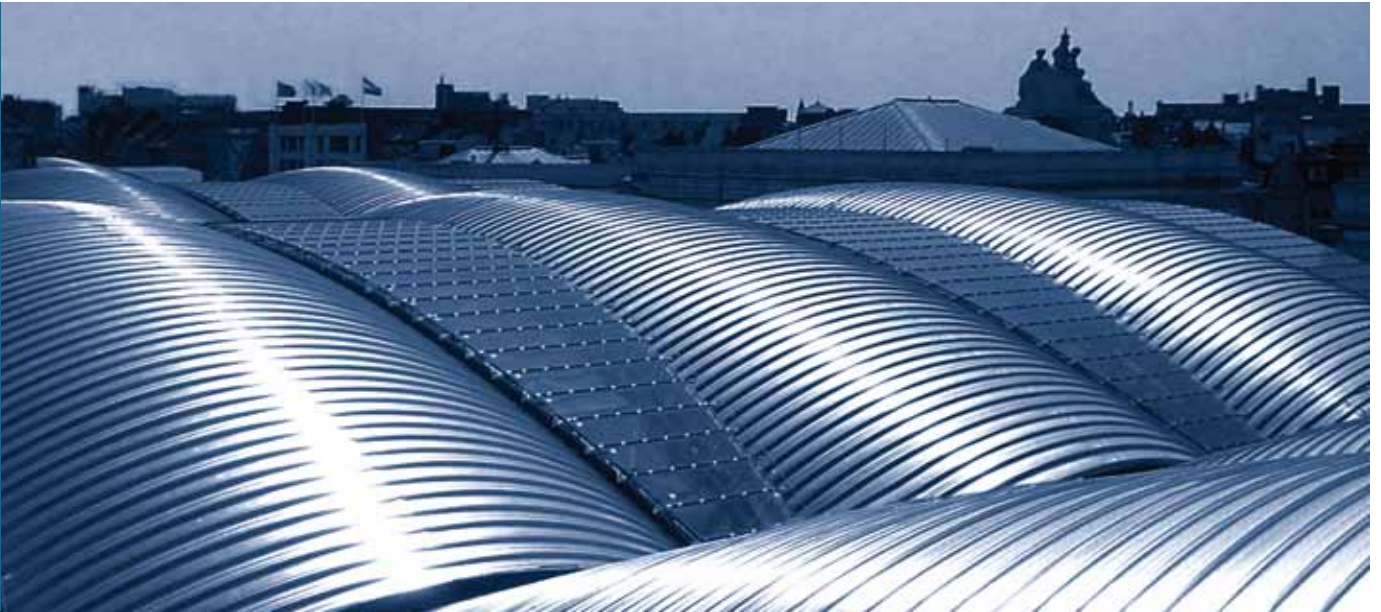

Architectural planning and building typologies are increasingly leaving behind the classic square shape. With selectable radiuses, two different arched profiles and an almost unlimited choice of colours, Hoesch's arched roof design provides solutions for truly dynamic architecture. The applications are almost endless: Sophisticated residential and administrative buildings, value for money, attractive covers for halls and car parks, grandstands, supermarkets, railway platforms and covers for public places, to name but a few....

Product features

- » Representative design
- » Individually adjustable to match the building
- » High stability and a flawless appearance thanks to crease-free production
- » Free unsupported spans of up to 20 m (double sheet design)
- » Single or double sheet design with thermal insulation or with acoustic perforation
- » Affordable thanks to industrial prefabrication
- » Minimal weight

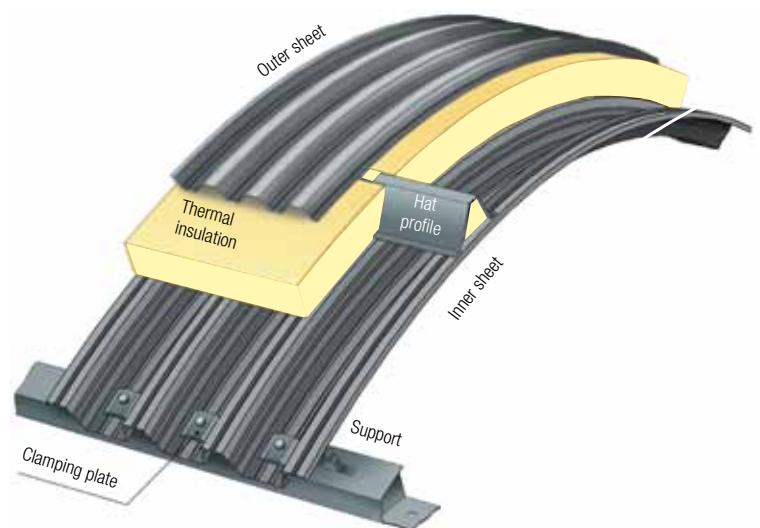



Simply more

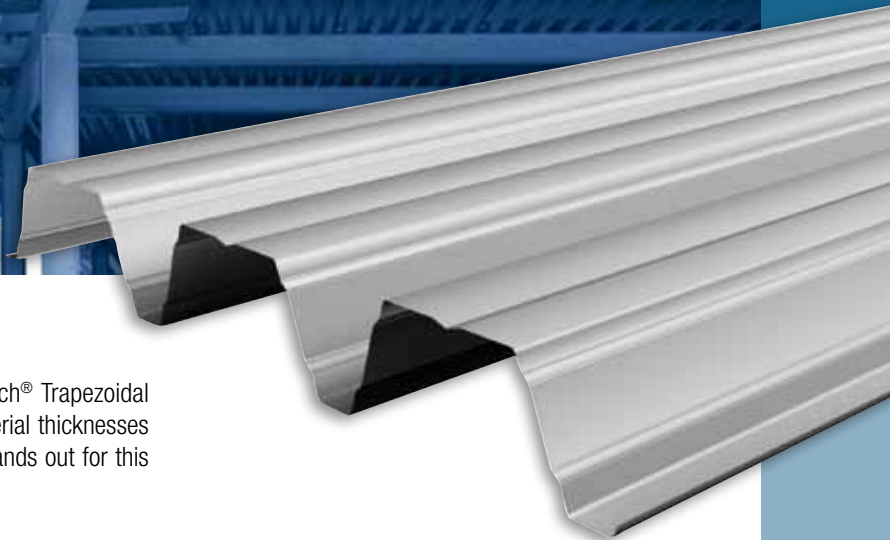

Take advantage of the wealth of possibilities offered by Hoesch® Trapezoidal Sheet. Whilst it comes in different textures, sheet heights, material thicknesses and panel lengths, single and doublesheet design, one thing stands out for this product: its high quality and unique versatility.

Product features

- » May be fitted in single or double sheet configurations
- » Sound reduction index of up to $R_w = 53$ dB possible
- » Anti-drip coating available
- » Acoustic roof profiles is inner sheet, perforated in the lateral chord
- » Individual insulation thickness and roof structures

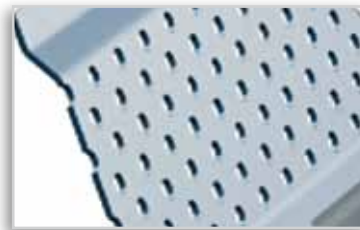

Perforated webs

Without anti-drip coating

Outside: cold air

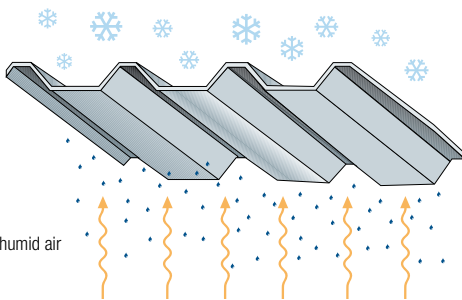

With anti-drip coating

Outside: cold air

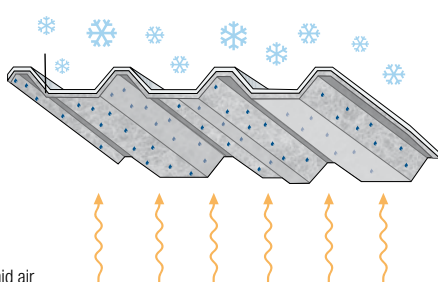

Opt for a sophisticated future
with wall systems made by Hoesch®



Flat



Microprofiled
(8 mm grid size)



V profiled
(16 mm grid size)



Slightly profiled



Wall Systems

- Hoesch® Thermowand
- Hoesch® Thermowand TL
- Hoesch isowand integral®
- Hoesch isowand integral® FSI
- Hoesch® isowand design
- Hoesch isowelle®
- Hoesch isowand vario®
- ems-isolier® Cold Store Panel PU
- Hoesch isorock®
- Hoesch isorock® vario
- Hoesch isorock® acoustic
- Hoesch® Polygon Arch
- Hoesch® trapezoidal profile
- Hoesch Planeel® Siding
- Hoesch® Corrugated Sheet
- Hoesch® Liner Tray

Fine feathers make fine birds. And fine façades make fine buildings. You have advanced architecture in mind. You invest in future-oriented, green concepts. You are driven by economical and holistic building concepts. Does this sound like you? Then our wall and façade elements are the ideal solution to meet your needs. Show that you care for humans and the environment. Our broad range of systems and solutions means that you can get exactly what you want to make a lasting impression, based on durable values. In addition, our wall and façade systems are not just attractive. They offer much more, giving you the reassurance of having made the right choice.

- » Excellent insulation values
- » Precise joint geometry
- » PU rigid foam insulation core
- » Low dead weight
- » Well planned fastening options
- » Alternative cover sheet materials are available upon request
- » Large spans
- » Smart value-added accessories
- » For expert sandwich panel installation, we recommend using our mounting aid
- » Optimum resistance to weathering and corrosion
- » Mix and match systems
- » Fire classification as per EN 13501-1 with mineral wool insulation core and B-s1, d0 with
- » Vapour-tight cover sheets made from coil-coated coloured steel

Hoesch® Thermowand

The basis for economic construction

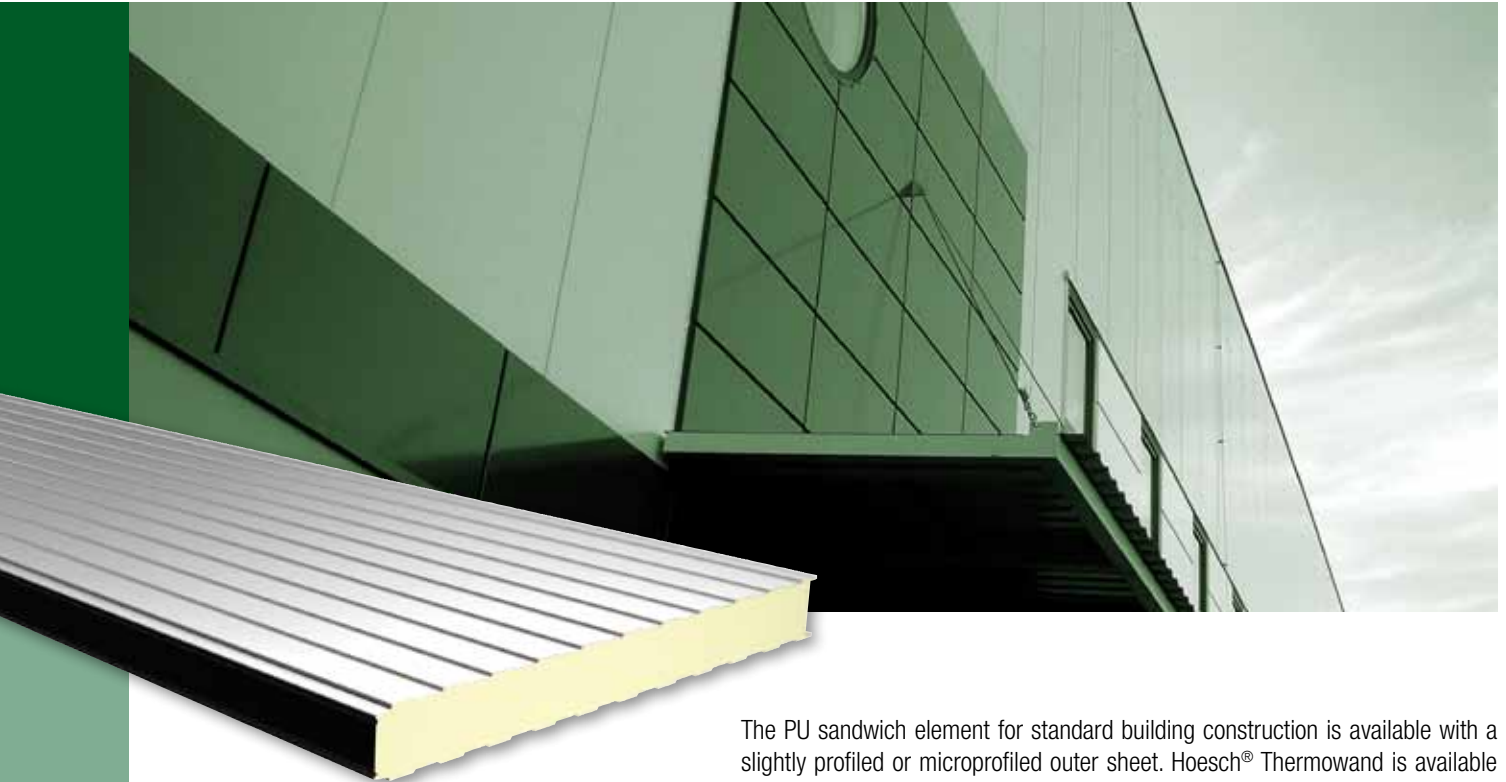

The PU sandwich element for standard building construction is available with a slightly profiled or microprofiled outer sheet. Hoesch® Thermowand is available with a cover width of 1000 mm or 1175 mm.

Product features

- » Through-bolt fastening
- » Fire classification B-s2, d0; standard C-s3, d0 as per EN 13501-1
- » General approval issued by the German building inspectorate (Z-10.4-533) and approvals issued by many foreign authorities
- » Factory-applied foamed sealing tape
- » Available in lengths up to 20 m
- » Available in panel thicknesses 40 mm, 60 mm, 80 mm, 100 mm and 120 mm
- » U-values according to EN 14509 from 0.56 to 0.19 W/m²K

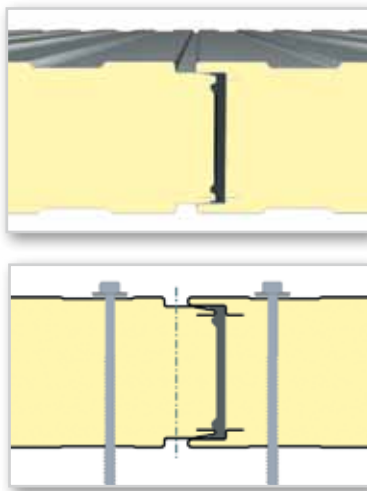

Deckschalen-profilierung	Slightly profiled (L)	Microprofiled (M)	V profiled (V)	Flat (E)
Outer sheet	●		■	
Inner sheet	●			

● available

For more technical information about the product, visit: www.hoesch-bau.com



Hoesch® Thermowand TL

Proven technology – worldwide in use



Hoesch® Thermowand TL is our proven PU sandwich panel with an external trapezoidal profile design. Extremely easy to install and engineered for large spans, Hoesch® Thermowand TL provides a reliable basis for outstanding results in terms of economical efficiency and functionality.

Product features

- » Through-bolt fastening
- » Fire classification to B-s2, d0; Standard C-s3,d0 in accordance with EN 13501-1
- » Factory-applied foamed sealing tape
- » General approval issued by the German building inspectorate (Z-10.49-533) and approvals issued by many foreign authorities
- » Vapour-tight cover sheets made from coloured, coil-coated steel
- » Available in lengths up to 24 m
- » Available in panel thicknesses 66 mm and 96 mm
- » U-values according to EN 14509 from 0.49 to 0.29 W/m²K

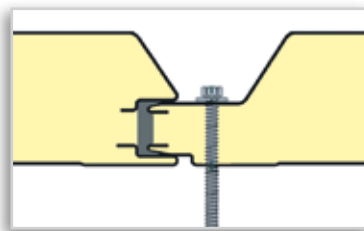
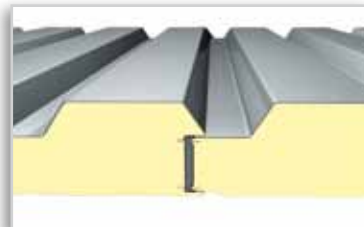

For more technical information about the product, visit:
www.hoesch-bau.com

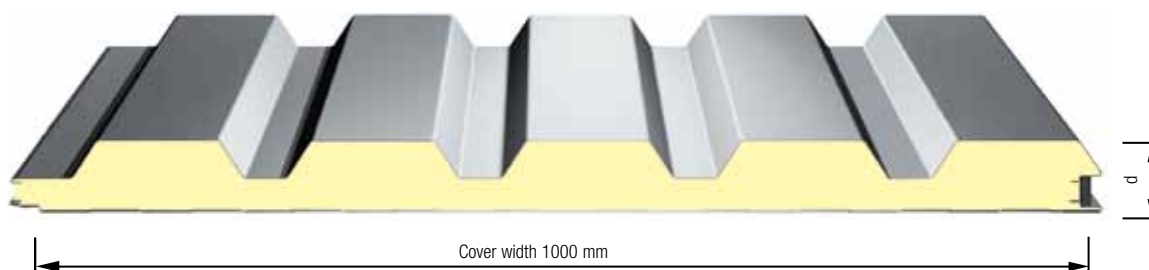

Hoesch isowand integral®

The flat façade panel for outstanding industrial architecture

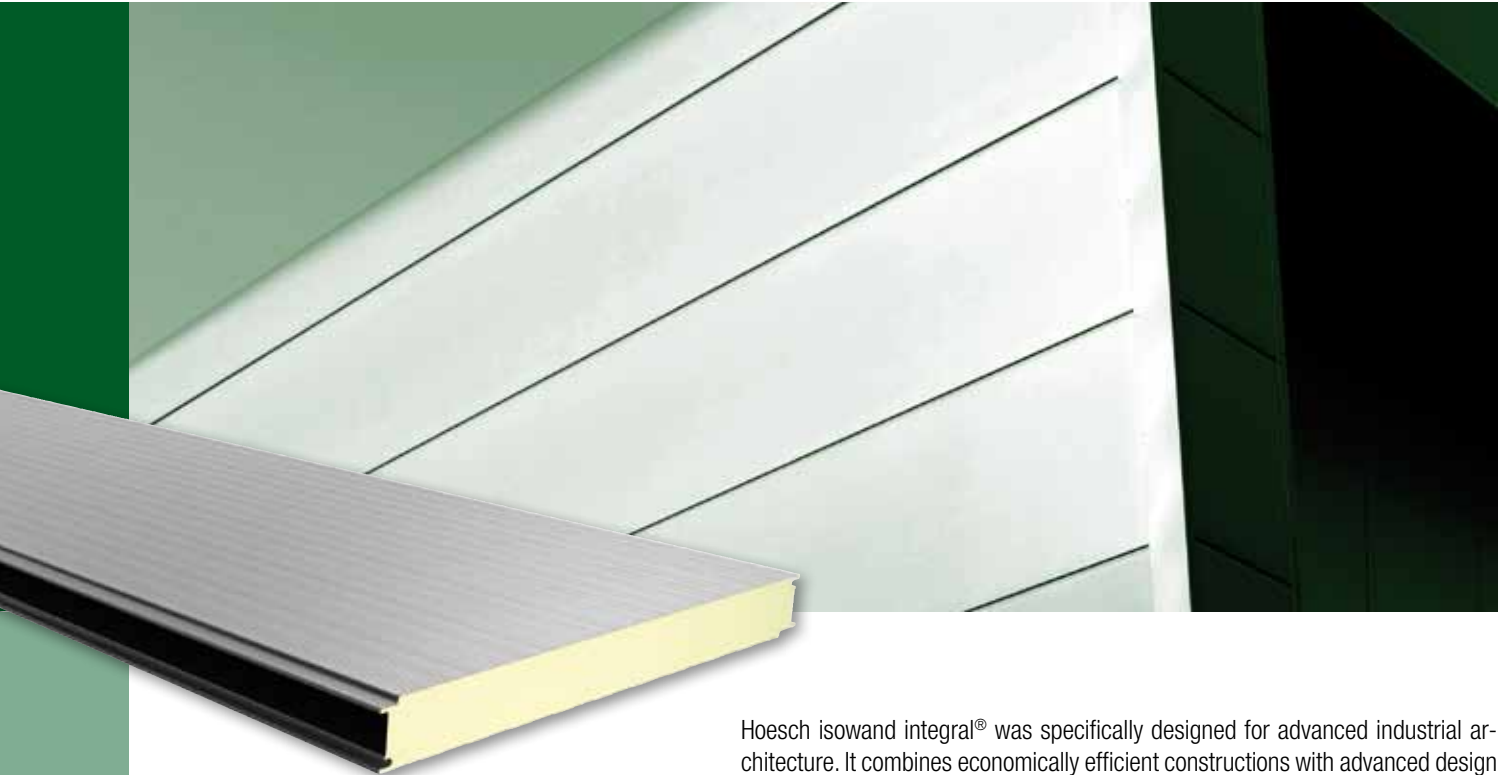

Hoesch isowand integral® was specifically designed for advanced industrial architecture. It combines economically efficient constructions with advanced design features. The panels feature concealed fastening using clips. The result: buildings with a distinctive edge that stand out. Hoesch isowand integral® is available with a flat, slightly profiled, microprofiled or V profiled surface.

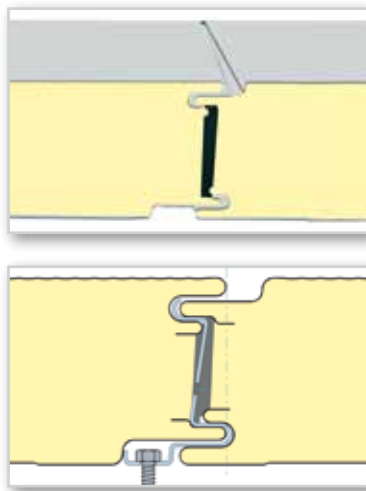

Product features

- » Concealed fastening with integral clips
- » Also available in cover widths of 600 mm, 900 mm, and 1200 mm
- » Special flashings for corners and parapets available
- » Attractive polygon effects can be created by turning the joints slightly
- » Simple replacement of single panels
- » General approval issued by the German building inspectorate (Z-10.49-533) and approvals issued by many foreign authorities
- » Fire classification up to B-s2, d0; standard B-s3, d0 in acc. with EN 13501-1
- » Flat, shapely panel system
- » Available in aluminium
- » Available in lengths up to 20 m
- » Available in panel thicknesses 60 mm, 80 mm, 100 mm and 120 mm
- » U-values according to EN 14509 from 0.45 to 0.19 W/m²K

For more technical information about the product, visit: www.hoesch-bau.com



Profiling of cover sheets	Slightly profiled (L)	Microprofiled (M)	V profiled (V)	Flat (E)
Outer sheet	●	●	●	●
Inner sheet	●			■

● available / ■ on request

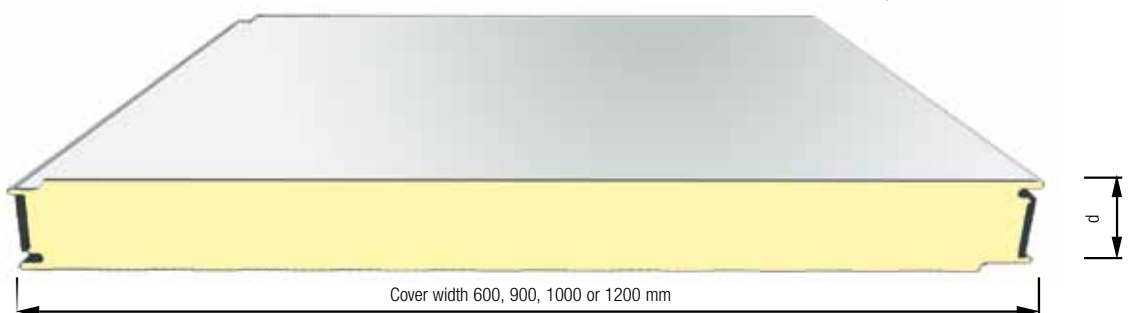



**The flat
panel system**



The curved and folded corner elements of Hoesch isowand integral® allow for stylish details.

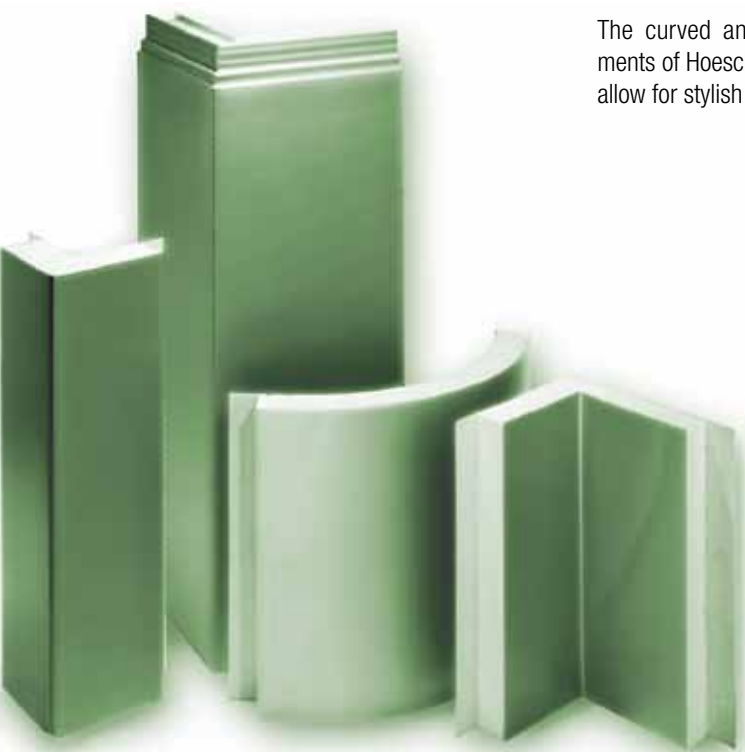

Hoesch isowand integral[®] with FSI window system

The façade system with perspective



Hoesch isowand integral[®] FSI is an innovative façade system that has been designed to match the successful Hoesch isowand integral[®] sandwich panel system perfectly. In cooperation with an internationally renowned window system supplier, we have developed this system featuring optimum thermal insulation which accurately fits the tongue and groove of Hoesch[®] isowand integral panels. The window can be harmoniously integrated into horizontally installed Hoesch isowand integral[®] without interrupting the joint line. This avoids isotherm line breaks in the wall, minimizing thermal bridges in connection areas.

When designing the system, tight joints were our top priority. In this regard, the technical specifications and variants of joints and elements also apply to connection parts. Window connections are a very sensitive area. Therefore, we have worked out concepts with integral window systems. The profile geometry matches the joint and hence the panel joint. How you benefit: there is no loss of valuable heating or cooling energy.

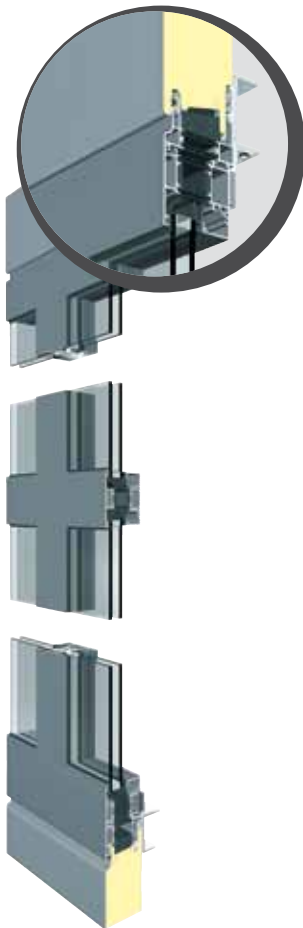

Product features

- » Standard designs prepared to install fixed glazing (24 mm, other dimensions available upon request)
- » A range of choices for powder coating, and different colours available for external and internal use
- » Can be ordered with fixtures for tilt and turn or hopper windows
- » Available with vertical and horizontal glazing bars
- » Attractive integration of windows into the complete façade
- » Solutions to connect any thickness



Hoesch® isowand design

Unlimited choice



Hoesch® isowand design leaves nothing to be desired. A variety of colours and surface textures gives room for creativity and bespoke designs. Hoesch® isowand design with concealed fastening can be laid either horizontally or vertically. The panels come with a fitted joint sealing tape which, combined with a polyurethane rigid foam core, provides maximum thermal insulation. Upon request, panels are supplied ready for installation in lengths up to 22 m, ensuring that you receive the maximum benefits in speed and design.

Product features

- » Broad choice of standard colours
- » Outer sheet microprofiled or V profiled
- » Concealed fastening
- » Fire classification C-s3, d0 in accordance with EN 13501-1

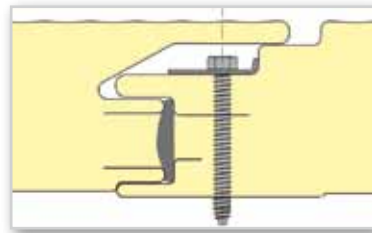

Profiling of cover sheets	Slightly profiled (L)	Microprofiled (M)	V profiled (V)	Flat (E)
Outer sheet		●	●	
Inner sheet	●			

● available



Hoesch isowelle®

Take a fresh design approach

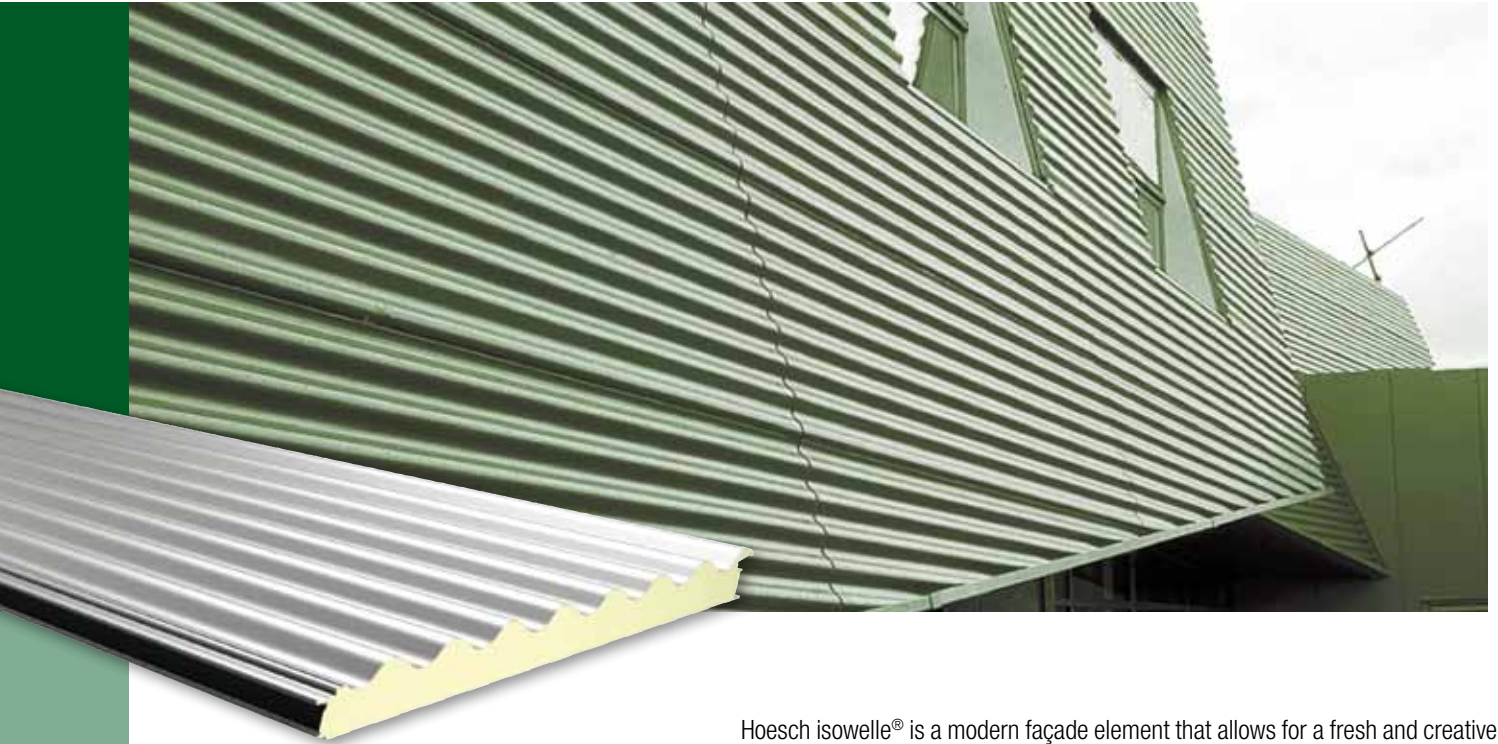

Hoesch isowelle® is a modern façade element that allows for a fresh and creative approach to wall design. Hoesch isowelle® can be easily combined with Hoesch isowand vario®, giving you even more design options.

Product features

- » Attractive, modern design
- » Vapour-tight cover sheets made from coil-coated coloured steel
- » Can be combined with Hoesch isowand vario® due to identical joint geometries
- » Fire classification up to B-s2, d0; standard C-s3, d0 in accordance with EN 13501-1
- » General approval issued by the German building inspectorate (Z-10.49-533) and approvals issued by many foreign authorities
- » Available in lengths up to 20 m
- » Available in panel thicknesses 84 mm and 104 mm
- » U-values according to EN 14509 from 0.36 to 0.26 W/m²K



For more technical information about the product, visit: www.hoesch-bau.com

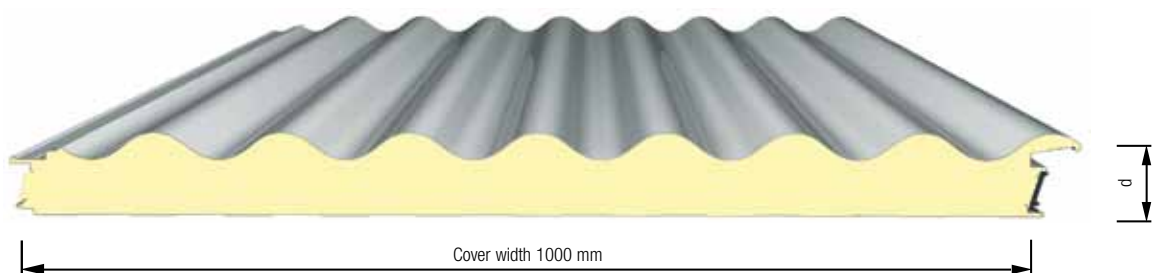

Hoesch isowand vario®

Bring life to your façades



Hoesch isowand vario® creates lively, varied façades. It can be easily combined with Hoesch isowelle®, highlighting architecture with proven quality.

Product features

- » Precise cover widths due to defined stops and grooves for aligned screw fastening
- » Special elements for corner and parapet connection available
- » Fire classification up to B-s2, d0; standard C-s3, d0 in accordance with EN 13501-1
- » General approval issued by the German building inspectorate (Z-10.49-533) and approvals issued by many foreign authorities
- » Available in lengths up to 20 m
- » Available in panel thicknesses 80 mm, 100 mm, 120 mm and 140 mm
- » U-values according to EN 14509 from 0.43 to 0.16 W/m²K

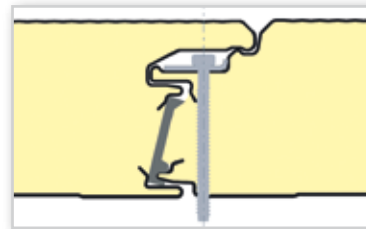

For more technical information about the product, visit: www.hoesch-bau.com

Profiling of cover sheets	Slightly profiled (L)	Microprofiled (M)	V profiled (V)	Flat (E)
Outer sheet	●	●	●	
Inner sheet	●			

● available

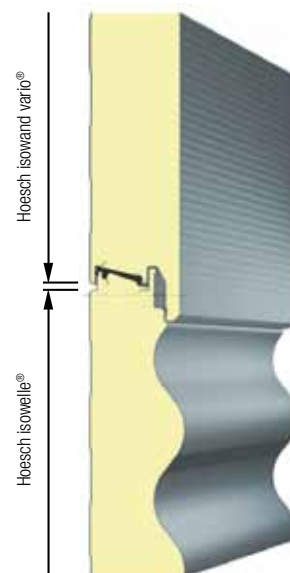
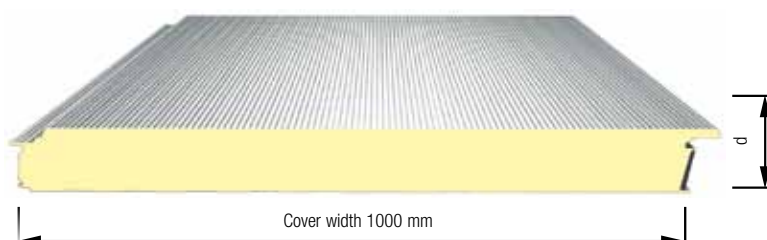

ems-isolier® cold store panel PU

Stay cool



Whether for positive temperatures, freezing or shock freezing chambers, ems-isolier® cold store panels have been a standard in cold store construction over decades, consistently complying with customers' requirements. Ten different element thicknesses ranging from 40 to 220 mm are available. The specific joint geometry designed for cold stores (from PU 60) creates a tight labyrinth seal, ensuring that the joints are sealed with the required tightness even at the lowest temperatures with no need for additional sealing components. To achieve vapour diffusion tightness, you may add ems-isolier® ELAST sealing compound. Which is particularly suited for ultra-low refrigeration, clean room, and CA/ULO storage applications.

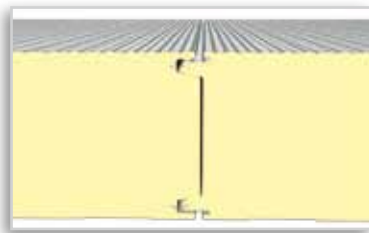
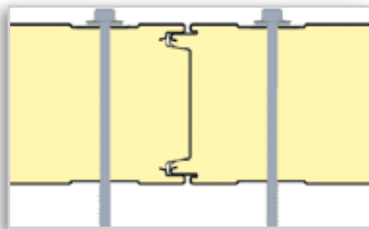

Product features

- » Also available in stainless steel
- » available with anti-fingerprint surface
- » Double tongue and groove connection (labyrinth seal) from PU 60
- » Lengths up to 24 m available
- » Fire classification up to B-s1, d0; in accordance with EN 13501-1
- » FS 3000® foodsafe surface coating optional
- » General approval issued by the German building inspectorate Z-10.49-524 (PU cold store panel)
- » Available in panel thicknesses from 40 mm to 220 mm
- » U-values according to EN 14509 from 0.58 to 0.11 W/m²K

For more technical information about the product, visit: www.hoesch-bau.com

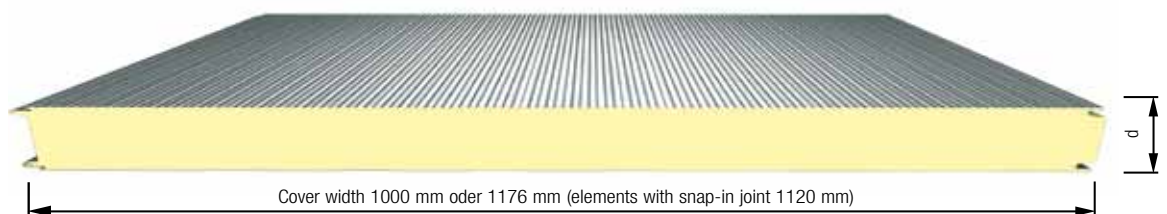
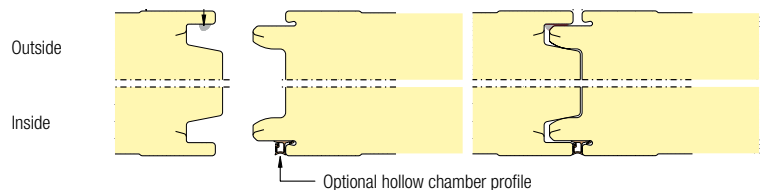



Positive-locking joint

Due to the snap effect the correct stop position of the ems-isolier® panels at the longitudinal joint of the elements is clearly defined. Snapping the elements into the joint ensures tightness of the joint.

Accuracy of fit

The accuracy of fit of the elements is ensured during production by the use of particular profiles for the joint, which considerably eases installation.

Adjustable snap-in effect

The extent of the snap-in effect is defined by the length of the elements.

Retention effect

For element lengths up to 4000 mm the snap-in effect ensures a self-supporting structure without the need for an additional substructure. This is ideal for the construction of large cells or rooms. This retention effect arising from the snap-in joint is unique and is protected by patent.

Improved joint stability

The new joint geometry offers enhanced stability and gives the joint a more homogeneous visual appearance.

Behaviour of the snap-in joint in fire

To ascertain the behaviour in fire B-s1, d0, please contact our sales staff.

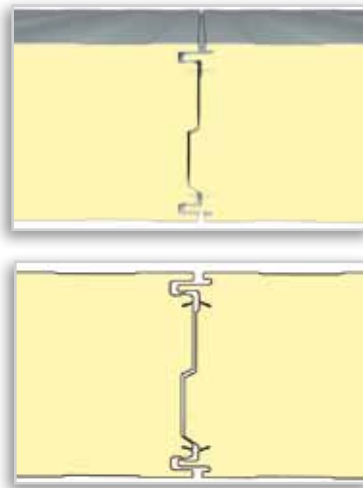

With ems-isolier® snap-in joints, fitting ems-isolier® cold store panels is a piece of cake.

Please note: The snap-in joint is available with an element thickness of 100 mm, 150 mm and 200 mm.

Profiling of cover sheets	Slightly profiled (L)	Microprofiled (M)	V profiled (V)	Flat (E)
Outer sheet	●		●	■
Inner sheet	●			■

● available / ■ on request



ems-isolier® PU cold store panel

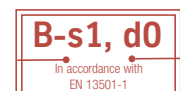

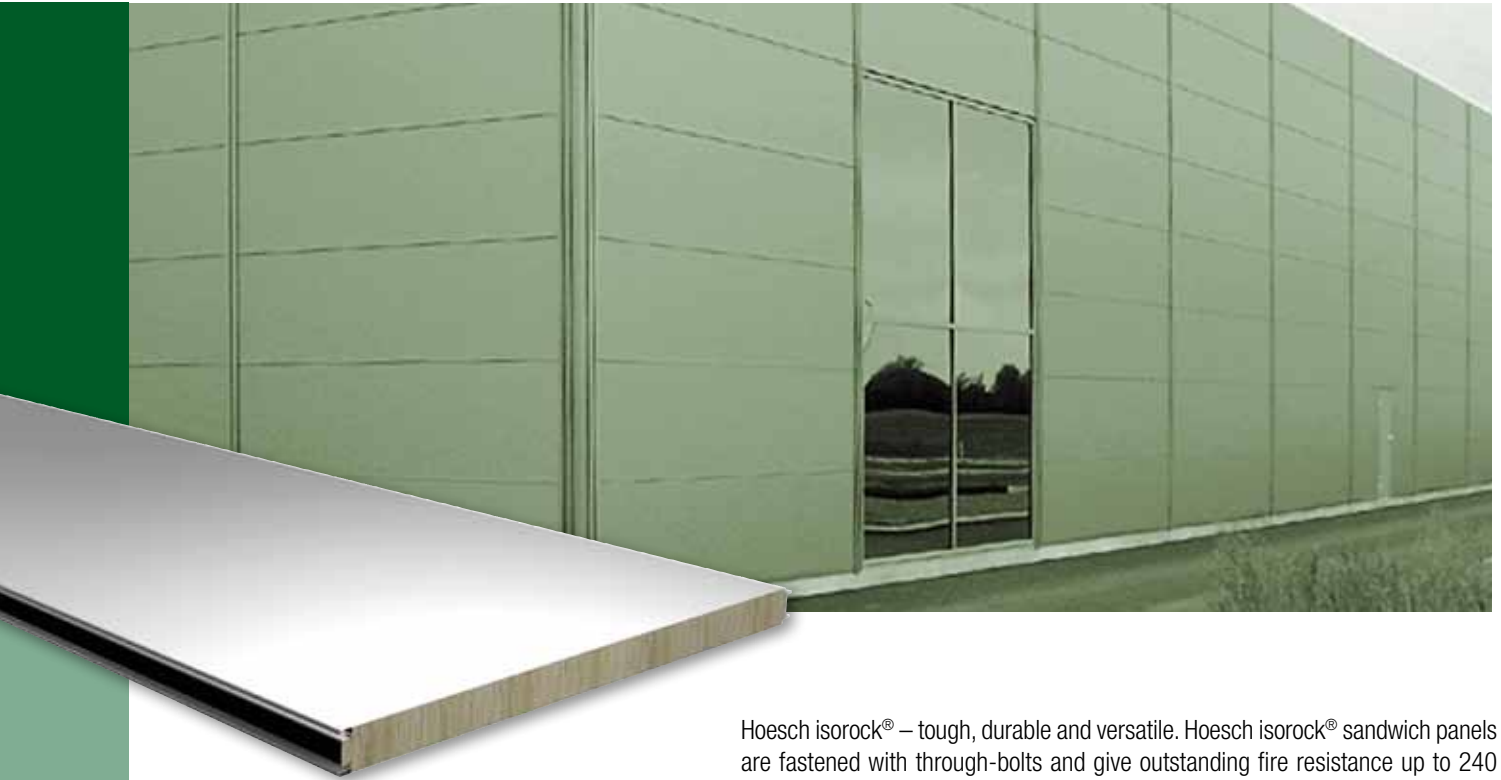

Hoesch isorock® – tough, durable and versatile. Hoesch isorock® sandwich panels are fastened with through-bolts and give outstanding fire resistance up to 240 minutes. Hoesch isorock® panels may also be used as firewalls inside buildings.

Product features

- » Defined fire resistances classes between 30 and 240 minutes, measured on the basis of German and European standards
- » Sandwich element with the classification A2-s1, d0 “non combustible”, according to EN 13501-1
- » Physiologically harmless rockwool core with fire resistance classification A1, “non combustible”, according to EN 13501-1
- » Use as inner fire wall in accordance with the national regulations for industrial buildings is possible
- » In a test, insulation against airborne noise as per DIN EN ISO 140-3 and DIN EN ISO 717-1 a value of $R_w = 32$ dB was achieved
- » Lengths up to 16 m, panel thicknesses from 60 mm to 200 mm
- » High resistance to air leakage achieved by factory-applied sealing tapes
- » Also available in stainless steel and stainless steel with an antifingerprint surface
- » S 3000® foodsafe surface coating optional
- » General approval issued by the German building inspectorate (Z-10.49-534) and approvals issued by many foreign authorities
- » U-values according to EN 14509 from 0.72 to 0.21 W/m²K

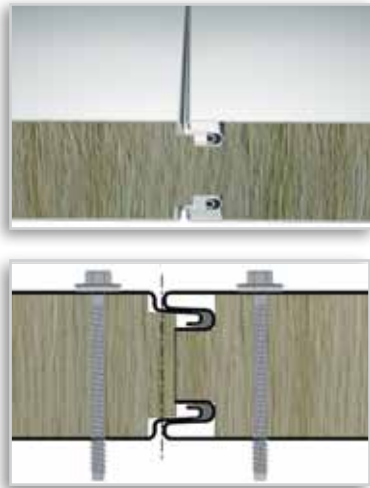

Profiling of cover sheets	Slightly profiled (L)	Microprofiled (M)	V profiled (V)	Flat (E)
Outer sheet	●	●	●	■
Inner sheet	●			■

● available / ■ on request

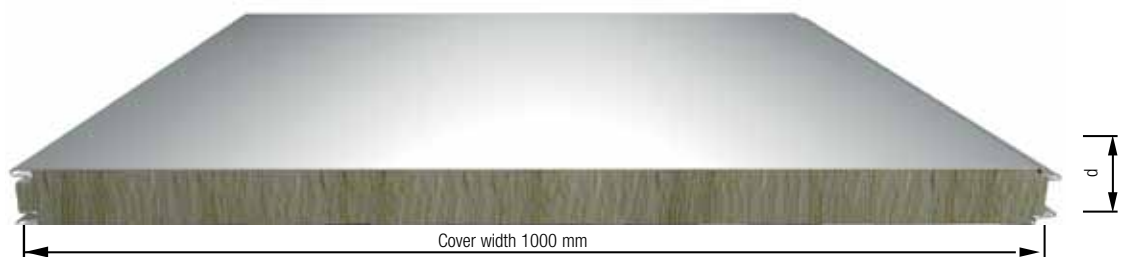

Hoesch isorock[®] vario

Fire protection made attractive



Hoesch isorock[®] vario sandwich panels are a high quality, high performance choice for façades with optimum fire protection. Concealed fastening and a design identical to isowand vario[®] make these panels even more attractive.

Product features

- » Defined fire resistances classes between 30 and 120 minutes, measured on the basis of German and European standards
- » Sandwich element with the classification A2-s1, d0 “non combustible”, according to EN 13501-1
- » Physiologically harmless rockwool core with fire resistance classification A1, “non combustible”, according to EN 13501-1
- » Use as inner fire wall in accordance with the national regulations for industrial buildings is possible
- » In a test of the insulation against airborne sound as per DIN EN ISO 140-3 and DIN EN ISO 717-1 a value of $R_w = 32$ dB was achieved
- » Lengths up to 16 m, panel thicknesses from 80 mm to 200 mm
- » High resistance to air leakage achieved by factory-applied sealing tapes
- » Delivered ready for installation
- » Also available in stainless steel and stainless steel with an antifingerprint surface
- » FS 3000[®] foodsafe surface coating optional
- » General approval issued by the German building inspectorate (Z-10.49-534) and approvals issued by many foreign authorities
- » U-values according to EN 14509 from 0.58 to 0.22 W/m²K

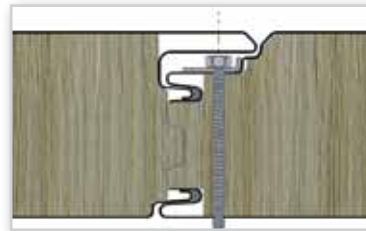

Image left:
Cover width $d \geq 100$ mm

Profiling of cover sheets	Slightly profiled (L)	Microprofiled (M)	V profiled (V)	Flat (E)
Outer sheet	●	●	●	■
Inner sheet	●			■

● available / ■ on request



Hoesch isorock® acoustic

A noise absorber with non combustible insulating core



Noise can cause serious damage to your health and preventive action is very important. Hoesch isorock® acoustic sandwich panels with rockwool insulating core and special acoustic perforation are specifically designed for indoor applications. They feature outstanding sound absorption values to make sure noise stays outside. The panel is fastened with through-bolts and available in a range of colours, offering you maximum architectural design freedom.

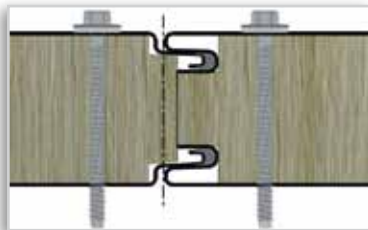

Product features

- » Physiologically harmless rockwool core with fire resistance classification A1, “non combustible”, according to EN 13501-1
- » Good insulation against airborne noise $R_w = 34$ dB, tested according to DIN EN ISO 140-3
- » Lengths up to 16 m
- » High rigidity despite perforated surface
- » Factory-applied sealing tape
- » For internal use
- » With metallic ZM EcoProtect coating also suitable for external use
- » General approval by the building inspectorate applied
- » U-values according to EN 14509 from 0.67 to 0.21 W/m²K

Profiling of cover sheets	Slightly profiled (L)	Microprofiled (M)	V profiled (V)	Flat (E)
Outer sheet	●	●	●	●
Inner sheet*				●

● available / ■ on request

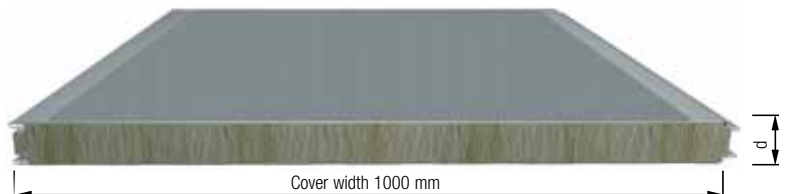
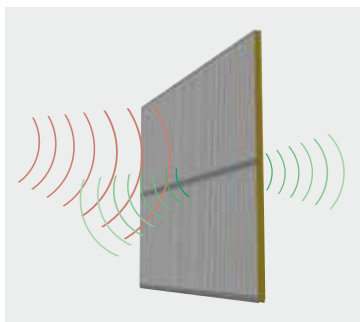

Hoesch® Polygon Arch

Looking for round corners?

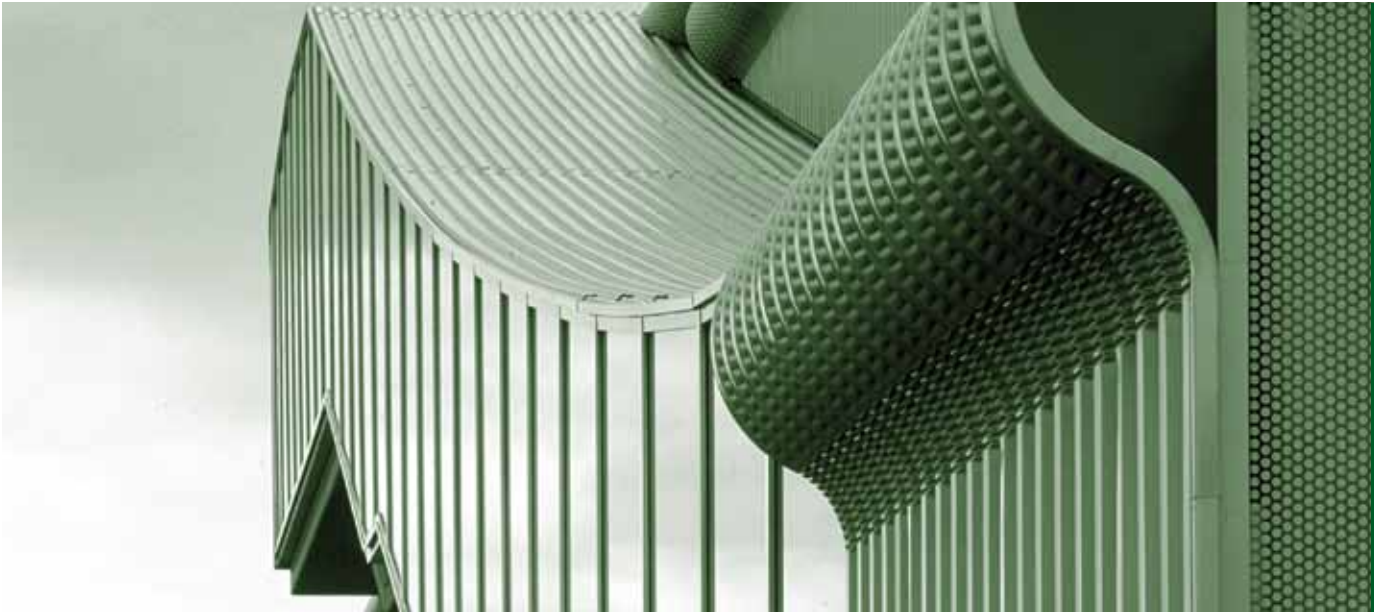

Whether your requirement is for rounded edge, radial roofing or a seamless transition in the parapet area, the Polygon Arch made by Hoesch® is a precise, tailored arch of perfect beauty. The possibility of combining trapezoidal profiles with the Hoesch® Polygon Arch mean architects benefit from boundless options.

For even more design options or acoustic functions, you can choose the perforated Hoesch® Polygon Arch acoustic.

Product features

- » Available for the profiles HP 35K, HP 39K and HP 41K
- » Lengths up to 8 m
- » Radii from 150 mm
- » For horizontal and vertical installation
- » Also available with anti-drip coating

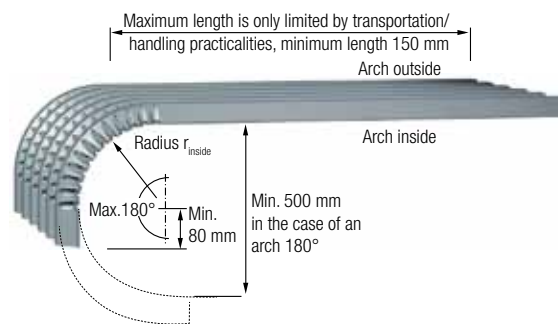

Building part	Profile Please note A and B side!	Material thickness	Min. radius A*	Min. radius B*	Bend angle**
		t_w mm	r_{inside} mm	$r_{outside}$ mm	
HP 35K (Ag)/207		0.63	500	150	14°
		0.75		180	14°
		0.88		200	9°
		1.00		200	9°
HP 41K (Ag)/160		0.63	500	200	8°
		0.75		200	8°
		0.88		200	8°
		1.00		250	7°

Please indicate which are the A and B sides (upper/lower side) in the case of different coatings. Panels of all thicknesses are supplied with protective foil. *If this side = outside of the arch ** For each notch max.

Hoesch® trapezoidal profile

An all-rounder with added value

Also available as Roof (P. 15) and Floor!



Hoesch® trapezoidal profiles adapt to meet your requirements. The attractive, large-surface construction element is installed on Hoesch® Liner Trays or adjustable Hoesch substructures. It can be combined with Hoesch® Polygon Arches or perforated trapezoidal profiles. Along with innovative coatings and a virtually unlimited choice of colours, you get a unique façade design.

Product features

- » Sound insulation values with a multi-sheet design of up to $R_w = 54$ dB
- » Economic installation on Hoesch® Liner Trays and adjustable Hoesch substructures
- » Can partially be combined with a polygon arc and perforated profiles
- » When combined with a Hoesch substructure, insulation values up to passive-house standard can be achieved

Building part	Trapezoidal building parts according to DIN 18807 Please observe the A and B sides!	Max. length supplied m	Material thickness t_N m	Weight kg/m ²
T 35.1		18.0	0.63	6.01
			0.75	7.16
			0.88	8.40
			1.00	9.55
T 35.1D		18.0	0.63	6.09
			0.75	7.25
			0.88	8.50
T 40.1		18.0	0.63	6.80
			0.75	8.10
			0.88	9.50
			1.00	10.80
T 40.1D		18.0	0.63	6.89
			0.75	8.20
			0.88	9.62
T 40.1S		18.0	0.75	8.10
			0.88	9.50
			1.00	10.80
T 50.1		18.0	0.63	6.30
			0.75	7.50
			0.88	8.80
			1.00	10.00
			1.25	12.50
			1.50	15.00

Table on the right:

Please indicate which are the A and B sides (upper side, lower side) in the case of different coatings.

Hoesch® acoustic

Perforated elements for a variety of applications



Perforated Hoesch® trapezoidal sheets

Stylish sound insulation. Our perforated sheets are attractive products with application possibilities well beyond sound insulation. In single sheet design, perforated sheets are frequently used to provide shade, to secure parapets or to provide view protection. Other than in the case of expanded metal or stainless steel mesh, the smoothly perforated holes prevent dirt and dust from accumulating. Depending on the level of perforation, they can be very transparent and allow for exciting views.

Hoesch Planeel® Siding*

An ideal line, now also available with perforation. Much like a theatre curtain, these economically efficient designs can be strategically staged to achieve thrilling light effects.

* more information on the pages 34-35

Hoesch® Liner Tray Acoustic**

A solid foundation. This has all the benefits of Hoesch® Liner Trays plus excellent sound absorption features. Hoesch® Liner Tray Acoustic has been designed for indoor applications.

** more information on page 37



Discover the versatile Hoesch Planeel® Siding. It can be used as a curtain-type façade element ventilated at rear and concealed fastening, horizontally, vertically, diagonally or with a shadow gap. Hoesch Planeel® Siding is in addition to the standard matte colors from the color collection “matt de luxe” optional also available in the color series pearl, stainless steel finish, or ReflectionsCinc ReflectionsOne.

Product features

- » Curtain-type façades, rear ventilated executable, vertical, horizontal or diagonal installation
- » Cover widths from 200 mm to 400 mm, lengths up to 8 m
- » Concealed fixing
- » Flat surface design
- » Installation on a conventional substructure
- » The elements are closed on the front face side (on request)
- » Individual designs for corners of buildings
- » Also available in perforated design
- » Steel or aluminum

Designation of building part	Cover width b mm	Material thickness Flat (E) t_N mm	Max. length supplied m	Profile height h mm
HPL 200	200	0.88 1.00	8.0	24.0
HPL 300	300	0.88 1.00		
HPL 400	400	1.00		

At request with or without edge folding.

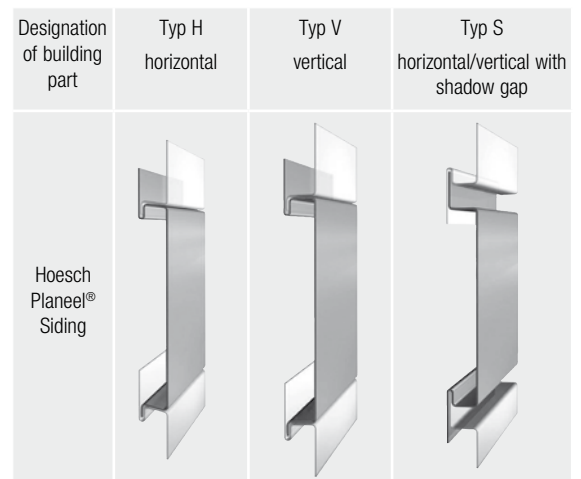



Adjustable Hoesch sub-structure for all substrate types. Façade installation by hooking into the system strip. Each element is fastened only at one fixed point.

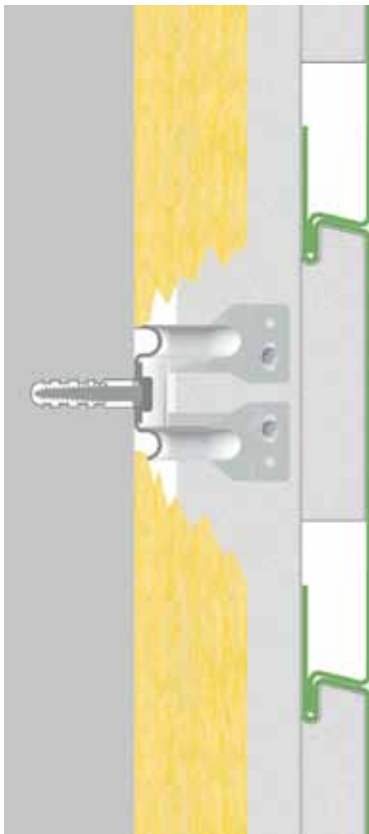

Hoesch Planeel installed on a system strip and a liner tray wall.

Hoesch® Corrugated Profile

A wave of enthusiasm

Also available as Roof and Floor element!

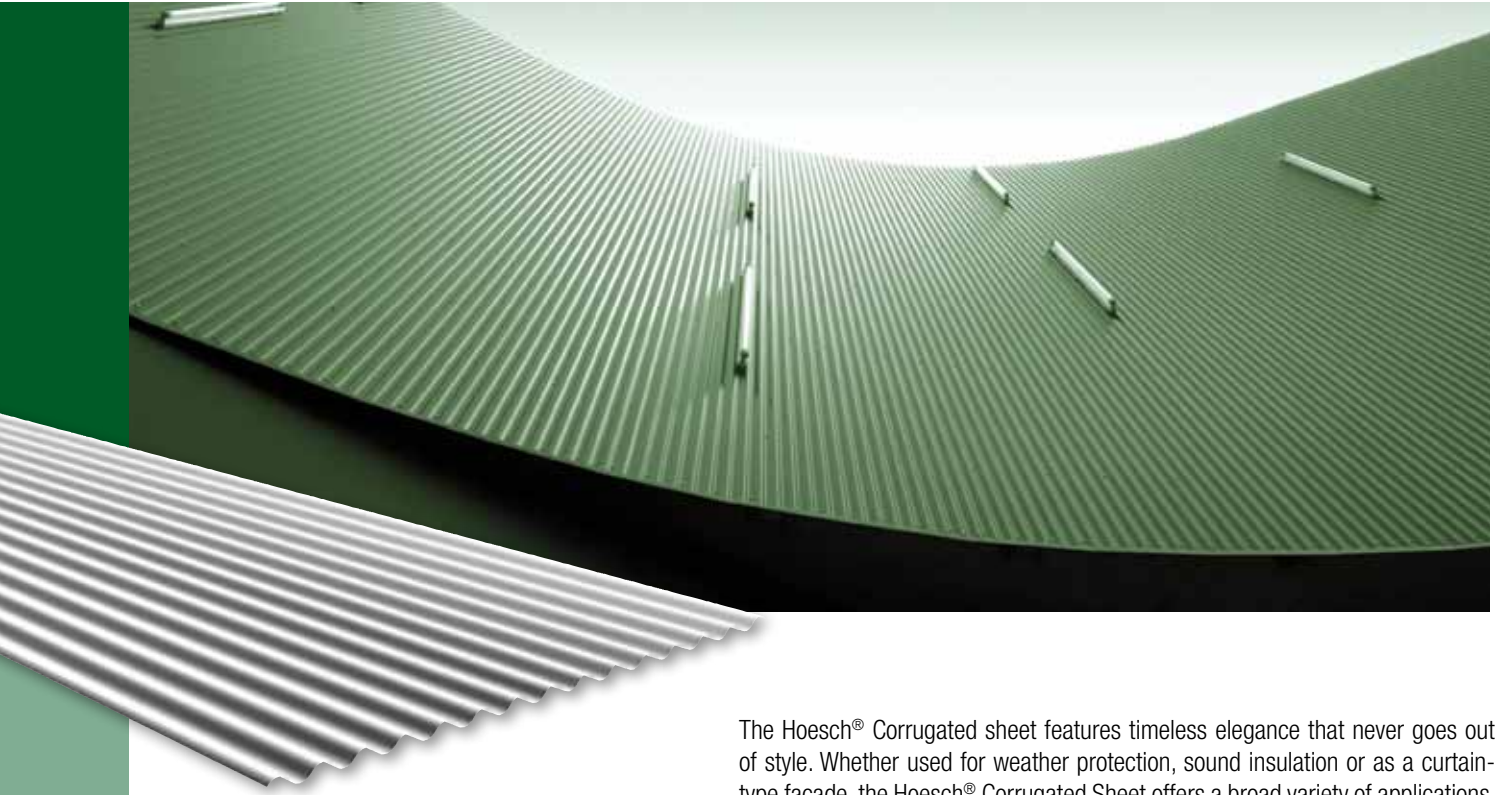

The Hoesch® Corrugated sheet features timeless elegance that never goes out of style. Whether used for weather protection, sound insulation or as a curtain-type façade, the Hoesch® Corrugated Sheet offers a broad variety of applications. A common feature in contemporary design is diagonal cuts – a feature that can be perfectly achieved with our corrugated sheet. When installed in ransverse direction, it can also be laid radially.

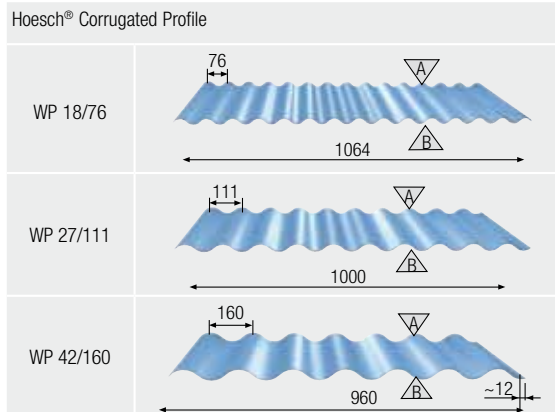

Hoesch® Corrugated Profile 18/76



Hoesch® Liner Tray

Bound by tradition

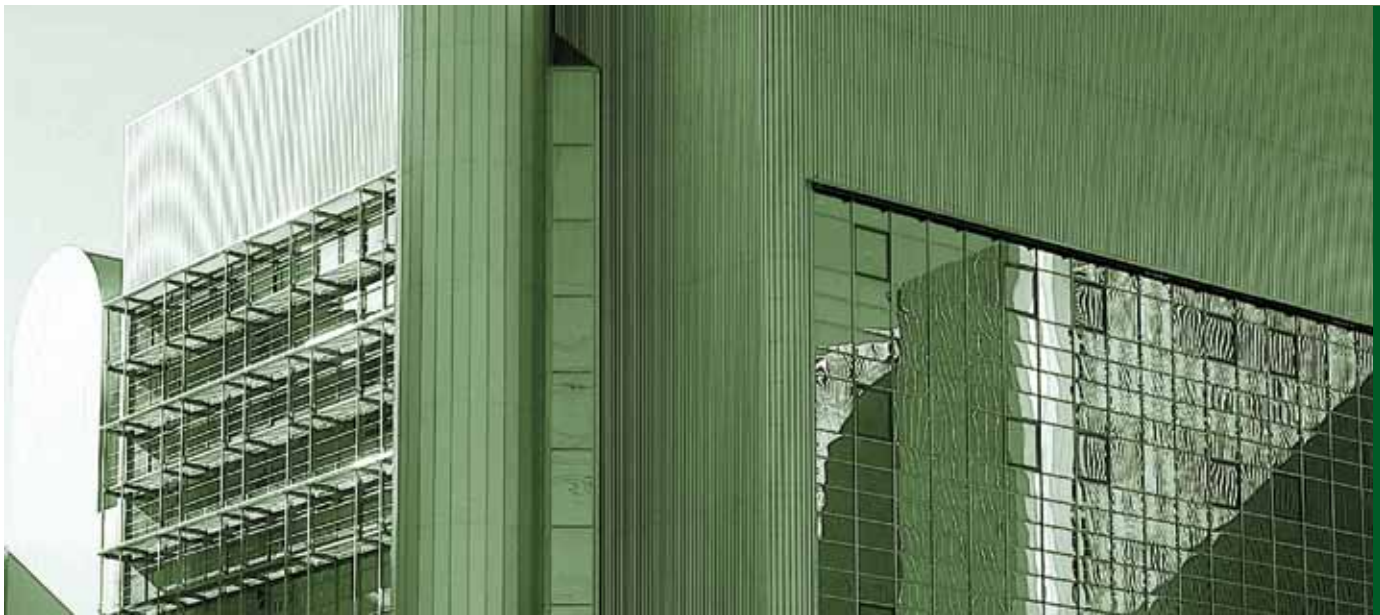

The proven system for classic double sheet walls for industrial and commercial buildings. The separation of internal and external sheet makes for excellent airborne sound insulation. The perforated design offers outstanding sound absorption.

Product features

- » In the case of double sheet design an airborne sound insulation index up to $R_w = 54$ dB is possible
- » The special wall design allows a fire resistance class W 90-A1 to be achieved
- » Spans up to 8.0 m are possible
- » Fewer horizontal rails are required
- » Available lengths up to 16 m

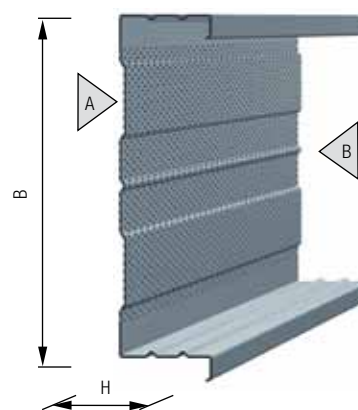
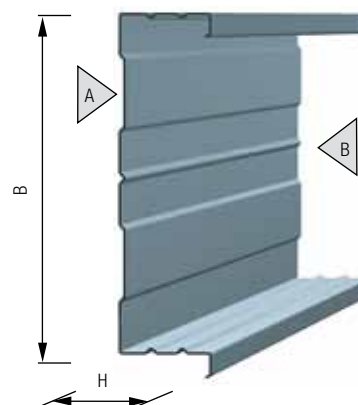

acoustic profile

Hole pattern

Percentage of holes 14.2 %

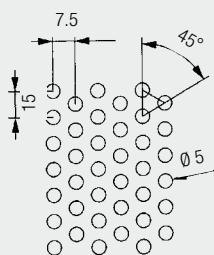

Covering for the future

with floor systems made by Hoesch®



Floor Systems

Hoesch Additiv Floor®

ems-isolier® cold store panel

Hoesch isorock®

When it comes to innovation, we are expected to look ahead. However, there are times when it is useful to change your perspective and look up. Mostly, what we see is fairly sterile floors. Let's put an end to that!

With floor profiles made by Hoesch Building Systems, you can change a plain floor into a true parking management system simply by using colours as guides. Go for a symbiotic combination of design, function and economics by choosing floor systems, which offer a variety of choices from basic floors to attractive eye catching designs for smart management systems.

- » Freely selectable coloured coatings
- » Individual constructions
- » Large spans
- » Maximum stability and safety
- » Easy and rapid installation
- » Short construction time

Hoesch Additiv Floor®

Unlimited thinking

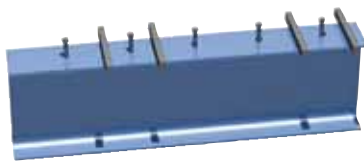

Hoesch Additiv Floor® is the leading system for classic steel/reinforced concrete construction in multi-storey buildings and car parks. Compared with solid floors, Hoesch Additiv Floor® excels as a result of the shorter construction time, which is typical for steel construction, as well as a clearly lower dead weight.

Smart guiding

Visual surfaces which are factory-coated in different colours help to achieve an easy optical separation of different floor levels.

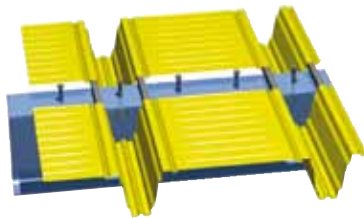

Product features

- » Floor system with official approval Z-26.1-44 / ETA 10/0113
- » Well proved over the past 20 years as an economically attractive system
- » Lightweight construction
- » Clear interjoist of up to 5.60 m
- » Patented supporting technique
- » Rapid and convenient installation of decking profiles without a crane
- » The various phases of construction can be carried out independently making for easy logistical planning
- » Decking profiles supplied with a factory applied coloured coating, excellently suitable as the exposed ceilings
- » F90 possible with additional reinforcement
- » Sustainability based on EN 1992-1-1
- » Possible loading of up to 5.0 kN/m²
- » No supports required in any construction phase

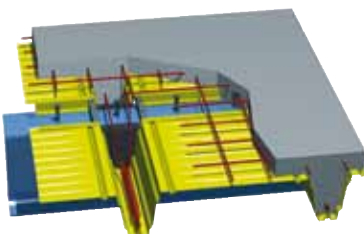
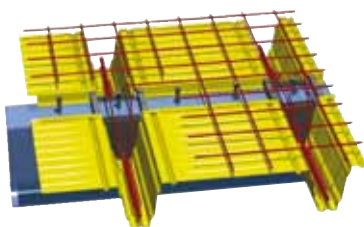



Today more than ever design engineers use prefabricated, high trapezoidal sheets for floor construction. This is just common sense, as these ensure short construction periods for the loadbearing structure in combination with large support distances. With additional reinforcement, Hoesch Additive Floor® complies with fire resistance class F90 – altogether an innovative concept which has much to offer in the way of economic effectiveness and architectural design. The system is suitable for car parks as well as floors and intermediate ceilings for offices and commercial buildings.

Hoesch profiled panels are the basic components of the Hoesch Additive Floor®. They can be used either for steel/reinforced concrete construction with girders or for classic steel constructions. Our patented system is unique because the profiled panels are suspended using solid steel brackets which have been welded onto the upper chord of the girder transversally to the girder direction, thereby offering a range of benefits. The floor is then completed by adding reinforcement and top concrete.

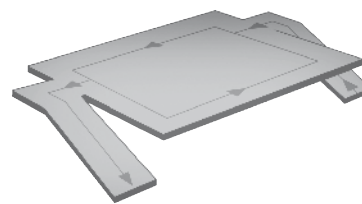

Parking level

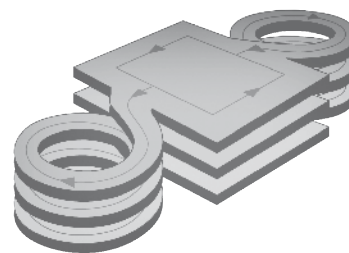

Single level car park

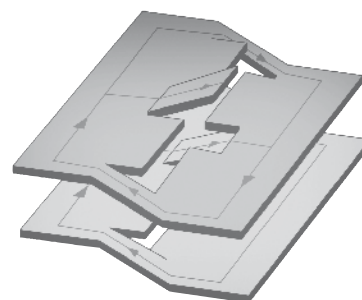

Split level car park

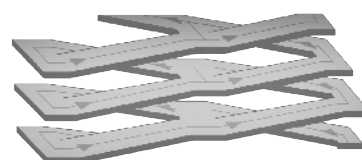

Car park with ramps

ems-isolier® cold store panel PU

The cold store floor that delivers on its promise



Stay on the safe side, with ems-isolier® PU cold store panels. You can rely on proven technology and bespoke designs. Whether for a positive temperature, freezing or shock freezing – ems-isolier® PU cold store panels ensure constant temperatures.

Product features

- » Double tongue and groove connection (labyrinth seal) from PU 60
- » Fire classification up to B-s1, d0; in accordance with EN 13501-1
- » FS 3000® foodsafe surface coating optional
- » Lengths up to 24 m
- » U-values according to EN 14509 from 0.58 to 0.11 W/m²K

Profiling of cover sheets	Slightly profiled (L)	Microprofiled (M)	V profiled (V)	Flat (E)
Outer sheet	●		■	■
Inner sheet	●			■

● available / ■ on request

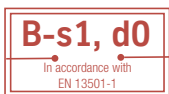
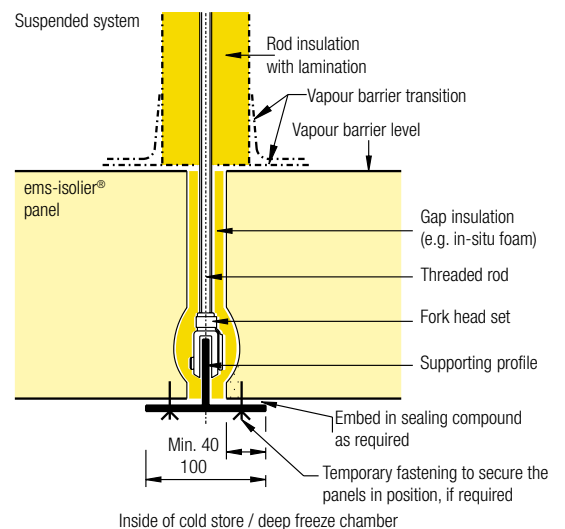

The floor with integral fire protection



Fire resistance classes defined by national and European standards meet all the requirements in terms of fire protection for suspended ceilings.

Product features

- » Sandwich element with the classification A2-s1, d0 "non combustible", according to EN 13501-1
- » Bio-degradable rockwool core with fire resistance classification A1, "non combustible", according to EN 13501-1
- » Precise joint geometry with factory-applied foamed sealing tape
- » Defined fire resistances classes on the basis of German and European standards
- » Rapid and easy installation
- » Vapour-tight cover sheets made from coloured, coil-coated steel
- » U-values according to EN 14509 from 0.67 to 0.28 W/m²K
- » Fire protection class EI30 in the form of a self-supporting suspended ceiling as per EN 13501-2, with a maximum span of 4.40 m (d ≥ 100 mm)



Element thickness
d = 60 mm

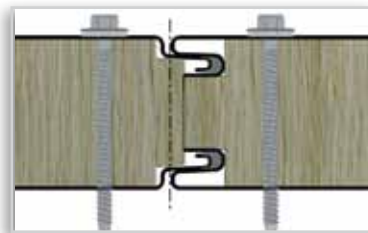

Element thickness
d ≥ 80 mm

Profiling of cover sheets	Slightly profiled (L)	Microprofiled (M)	V profiled (V)	Flat (E)
Outer sheet	●	●	●	■
Inner sheet	●			■

● available / ■ on request



A sustainable coating for the future
with coating systems made by Hoesch®



Coating Systems

Style must be learned.

It requires high quality standards which are constantly applied and continuously improved.

This is our policy for surface protection of building elements. Our high grade raw materials with durable coatings – ensure we can uphold our claim. Hoesch Building Systems elements usually have a metallic coating plus an organic coil coating.

This gives perfect protection against corrosion. What is more, the duplex system means there is an outstanding choice of colours for you to have maximum design freedom in order to realize your own ideas. Take advantage of our surface finishing expertise and our wealth of coatings designed to meet the needs of different application areas.

Everything you need for the future
with flashings and accessories made by Hoesch®



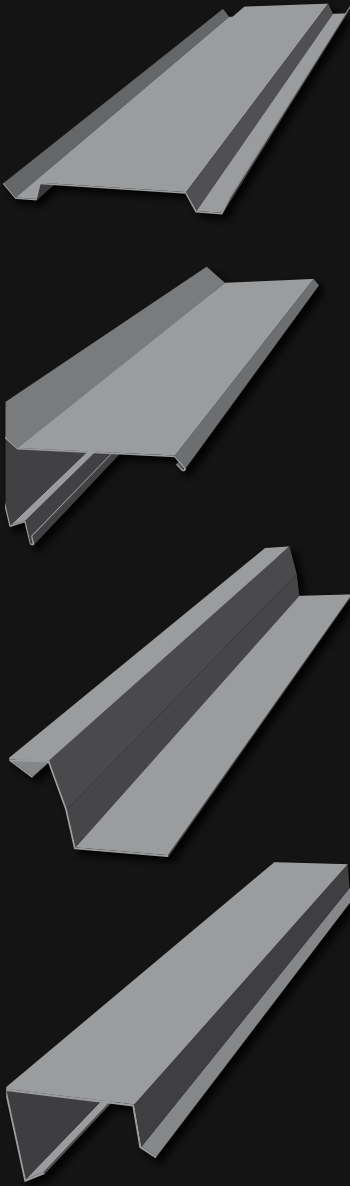

Flashings and Accessories

For your projects we offer a large range of flashings and accessories:

standard and special flashings up to 8 metres long and 3 mm thick.

Standard

Flashings frequently used for structures are offered as standard items. Their geometry, material thickness and coating are specially adapted to suit our building systems. Standard flashings are listed in a separate brochure. These parts can be ordered by quoting their reference number, without a sketch.

Special flashings

Flashings made to specification are termed as special flashings. They are tailor-made to accord with the customer's sketch which should contain all necessary information on dimensions, angles and coating.

Other advantages

- » Hoesch Building Systems offers a large range of colours to suit our roof and wall elements
- » Powder-coating and individually painted items are also possible
- » Specialist company with high production capacity
- » Short lead times, uncomplicated processes
- » Delivery together with the main order
- » Preforms are available up to 8 metres long and 3 mm thick
- » Small order quantities are acceptable

Hoesch Bausysteme GmbH // Hammerstraße 11 // D-57223 Kreuztal Germany
Phone: +49 (0) 27 32 599 1 599 // Fax: +49 (0) 27 32 599 1 271 // info@hoesch-bau.com // www.hoesch-bau.com



The information provided in this leaflet is subject to technical modifications. Details of features can be guaranteed only as far as these are explicitly confirmed in writing on a case by case basis.
GB-Info 1.1 - 12/2012